

New!

OMRON

CJ-series DC Power Supply Units

Slim-profile, Low-capacity Models

CJ1W-PD022

Advancing Downsizing and Flexibility with Low-capacity, Slim-profile CJ-series DC power Supply Units

Using the CJ1W-PD022 for PLCs driven with DC power reduces the overall PLC width and cuts the cost as well.



- Space-saving width of 27 mm
- Low cost

Ideal for Saving on Capacity, Cost, and Space to Meet Your Machine Requirements

CJ1W-PD022

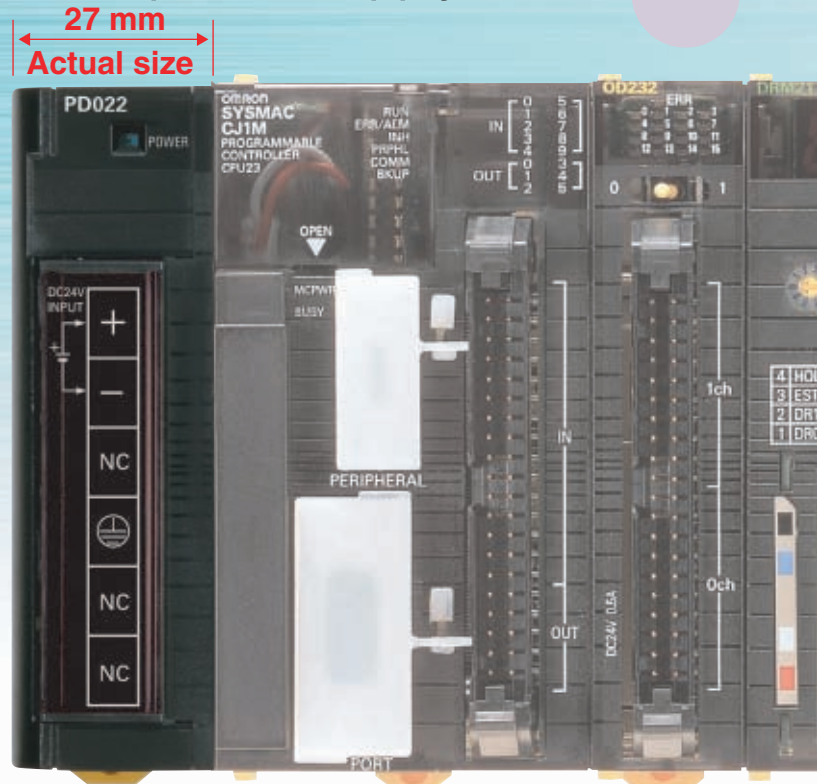

Proving powerful in system configurations with separate power supplies, offering solutions in applications requiring compact, low-cost power supplies.

Example: Combination with PT Power Supply

Need Using the surplus power from the PT power supply to drive the PLC when using only a PT and DeviceNet

The external 24-V power supply can also be used to drive the PT.

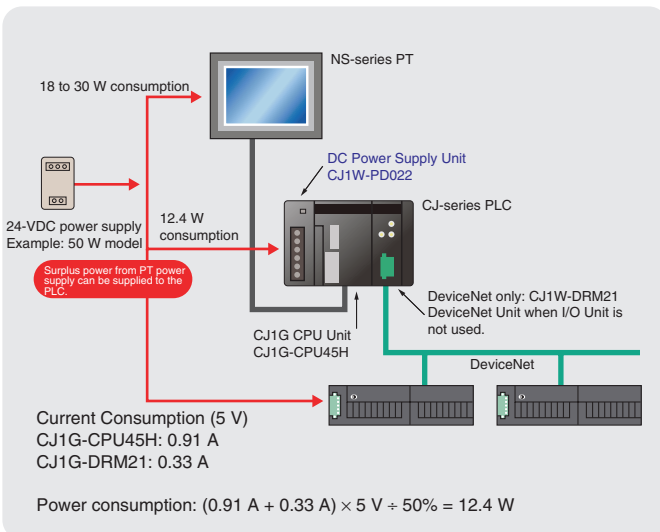

Example: Combination with Power Supply for Power Sensor

Need Achieving a compact, low-cost power supply in combination with I/O external power from a Power Sensor

Reduce overall size of power supply from 85 mm to 67 mm.

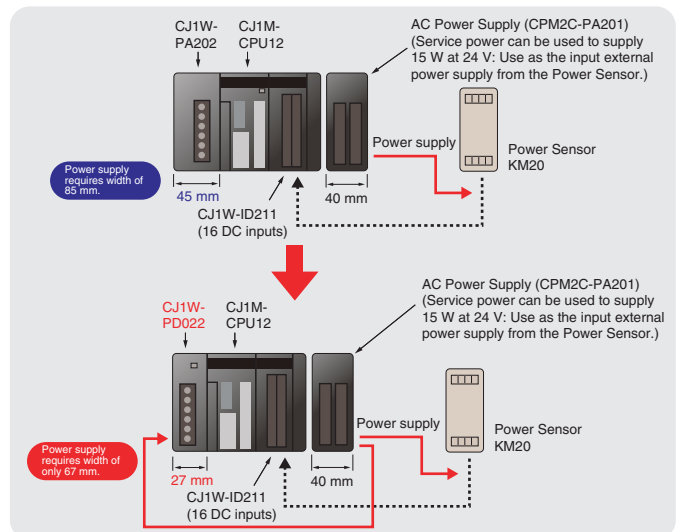

Lineup of Power Supply Units Meets a Range of Needs

■ CJ-series Power Supply Unit Specifications

Item	Specifications			
Power Supply Unit	CJ1W-PA205R	CJ1W-PA202	CJ1W-PD025	CJ1W-PD022 <i>NEW</i>
Supply voltage	100 to 240 VAC (wide-range)		24 VDC	
Operating voltage and frequency ranges	85 to 264 VAC, 47 to 63 Hz		19.2 to 28.8 VDC	21.6 to 26.4 VDC
Power consumption	100 VA max.	50 VA max.	50 W max.	35 W max.
Output capacity	5.0 A, 5 VDC (including supply to CPU Unit)	2.8 A, 5 VDC (including supply to CPU Unit)	5.0 A, 5 VDC (including supply to CPU Unit)	2.0 A, 5 VDC (including supply to CPU Unit)
	0.8 A, 24 VDC	0.4 A, 24 VDC	0.8 A, 24 VDC	0.4 A, 24 VDC
	Total: 25 W max.	Total: 14 W max.	Total: 25 W max.	Total: 19.6 W max.
RUN output (See note 1.)	Contact configuration: SPST-NO Switching capacity: 250 VAC, 2 A resistive load 120 VAC, 0.5 A (inductive load), 24 V DC, 2 A (resistive load) 24 V DC, 2 A (inductive load)	Not provided	Not provided	Not provided
Insulation resistance	20 MΩ min. (at 500 VDC) between DC external and GR terminals	20 MΩ min. (at 500 VDC) between AC external and GR terminals	20 MΩ min. (at 500 VDC) between DC external and GR terminals	--- (See note 2.)
Width	80 mm	45 mm	60 mm	27 mm
CJ-series CPU Rack dimensions (mm)	90.7 to 466.7 × 90 × 65 mm (W × H × D) (not including cables) Note: W = a + b + 20 × n + 31 × m + 14.7 ("a" depends on the Power Supply Unit: PA205R = 80, PA202 = 45, PD025 = 60, and PD022 = 27. "b" depends on the CPU Unit: CJ1-H/CJ1 = 62, CJ1M, CJ1M-CPU1□ = 31, and CJ1M-CPU2□ = 49. "n" is the number of 32-point Basic I/O Units or I/O Control Units and "m" is the number of other Units.)			

Note 1: Supported only when mounted to CPU Rack

Note 2: The CJ1W-PD022 is not insulated between the primary and secondary DC power supplies. When connecting personal computers or other peripheral devices to the PLC, be sure to consider the influence of the external power supply ground and peripheral device ground. (For details, refer to the *CJ Series PLC Operation Manual*.)

■ Ordering information

Unit	Applicable PLC Series	Specifications	Model
Power Supply Unit	CJ Series	24 VDC, output capacity: 2 A, 5 VDC	CJ1W-PD022

■ Dimensions

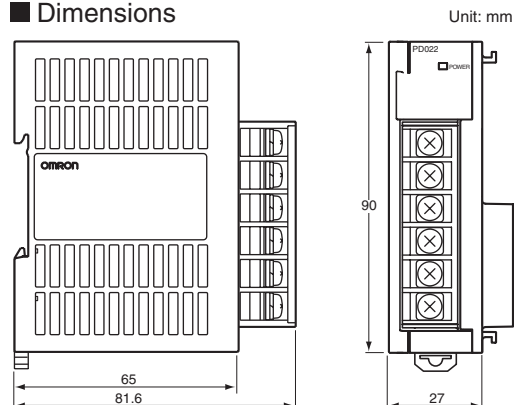

Warranty and Limitations of Liability

WARRANTY

OMRON's exclusive warranty is that the products are free from defects in materials and workmanship for a period of one year (or other period if specified) from date of sale by OMRON.

OMRON MAKES NO WARRANTY OR REPRESENTATION, EXPRESS OR IMPLIED, REGARDING NON-INFRINGEMENT, MERCHANTABILITY, OR FITNESS FOR PARTICULAR PURPOSE OF THE PRODUCTS. ANY BUYER OR USER ACKNOWLEDGES THAT THE BUYER OR USER ALONE HAS DETERMINED THAT THE PRODUCTS WILL SUITABLY MEET THE REQUIREMENTS OF THEIR INTENDED USE. OMRON DISCLAIMS ALL OTHER WARRANTIES, EXPRESS OR IMPLIED.

LIMITATIONS OF LIABILITY

OMRON SHALL NOT BE RESPONSIBLE FOR SPECIAL, INDIRECT, OR CONSEQUENTIAL DAMAGES, LOSS OF PROFITS, OR COMMERCIAL LOSS IN ANY WAY CONNECTED WITH THE PRODUCTS, WHETHER SUCH CLAIM IS BASED ON CONTRACT, WARRANTY, NEGLIGENCE, OR STRICT LIABILITY.

In no event shall the responsibility of OMRON for any act exceed the individual price of the product on which liability is asserted.

IN NO EVENT SHALL OMRON BE RESPONSIBLE FOR WARRANTY, REPAIR, OR OTHER CLAIMS REGARDING THE PRODUCTS UNLESS OMRON'S ANALYSIS CONFIRMS THAT THE PRODUCTS WERE PROPERLY HANDLED, STORED, INSTALLED, AND MAINTAINED AND NOT SUBJECT TO CONTAMINATION, ABUSE, MISUSE, OR INAPPROPRIATE MODIFICATION OR REPAIR.

This catalog mainly provides information that is necessary for selecting suitable models, and does not contain precautions for correct use. Always read the precautions and other required information provided in product operation manuals before using the product.

- The application examples provided in this catalog are for reference only. Check functions and safety of the equipment before use.
- Never use the products for any application requiring special safety requirements, such as nuclear energy control systems, railroad systems, aviation systems, medical equipment, amusement machines, vehicles, safety equipment, or other application involving serious risk to life or property, without ensuring that the system as a whole has been designed to address the risks, and that the OMRON products are properly rated and installed for the intended use within the overall equipment or system.

Note: Do not use this document to operate the Unit.

Printed on 100% Recycled Paper



Authorized Distributor:

OMRON Corporation
FA Systems Division H.Q.
66 Matsumoto
Mishima-city, Shizuoka 411-8511
Japan
Tel: (81)55-977-9181
Fax: (81)55-977-9045

Regional Headquarters
OMRON EUROPE B.V.
Wegalaan 67-69, NL-2132 JD Hoofddorp
The Netherlands
Tel: (31)2356-81-300/Fax: (31)2356-81-388

OMRON ELECTRONICS LLC
1 East Commerce Drive, Schaumburg, IL 60173
U.S.A.
Tel: (1)847-843-7900/Fax: (1)847-843-8568

OMRON ASIA PACIFIC PTE. LTD.
83 Clemenceau Avenue,
#11-01, UE Square,
Singapore 239920
Tel: (65)6835-3011/Fax: (65)6835-2711

Note: Specifications subject to change without notice.

Cat. No. R131-E1-01
Printed in Japan
1204-1M