

## TABLE OF CONTENTS

<b>TABLE OF CONTENTS</b> .....	<b>i</b>
<b>Section1 Outline of Sample Screen</b>	
1-1 Screen Configuration .....	1-1
1-2 Outline of Each Screen .....	1-2
<b>Section2 Operation Flow</b>	
2-1 Operation Flow .....	2-1
<b>Section3 Starting-up and Exiting the NS-Designer</b>	
3-1 Starting-up the NS-Designer .....	3-1
3-2 Exiting the NS-Designer .....	3-2
<b>Section4 STEP1 Creating a Simple Screen</b>	
4-1 Outline of the Screen to be created in STEP1 .....	4-1
Outline of screen 1 .....	4-1
Outline of sheet 1 .....	4-2
4-2 Creating a New Project .....	4-3
Opening a screen .....	4-6
4-3 System Setting .....	4-7
4-4 Host Registration .....	4-8
4-5 Screen Property Setting .....	4-9
4-6 Grid Setting .....	4-10
4-7 Creating Screen 1 .....	4-11
Creating functional objects .....	4-11
Creating functional objects using a table .....	4-15
Creating a fixed objects .....	4-19

## TABLE OF CONTENTS

### *NS series Tutorial Manual*

4-8 Saving a Screen	4-20
4-9 Creating Sheet1	4-21
Creating new sheet	4-21
Creating an object	4-23
Saving a sheet	4-23
4-10 Applying a Sheet	4-24
<b>Section5 STEP2 Debug</b>	
5-1 Test Function	5-1
Starting a test	5-1
Executing a test	5-2
5-2 Test Tool	5-3
5-3 Exiting a Test	5-5
<b>Section6 STEP3 Useful Functions</b>	
6-1 Outline of Screen to be Created in STEP3	6-1
Outline of screen2	6-1
Outline of screen3	6-3
Outline of a pop-up screen	6-4
6-2 Creating Screen 2	6-5
Creating a new screen	6-5
Alarm/Event setting	6-5
Creating a frame object	6-8
Editing a frame page	6-10
Creating a frame tab name	6-11
Creating functional objects an each frame	6-13

## TABLE OF CONTENTS

### *NS series Tutorial Manual*

6-3 Creating Screen3	6-22
Creating an object	6-22
6-4 Creating a Pop-up Window Screen	6-23
Creating an object	6-23
<b>Section7 STEP4 Creating Macro</b>	
7-1 Outline of Sample	7-1
Screen1	7-1
7-2 Registering a Macro	7-2
Registering a macro for set value	7-2
Registering a macro for a transfer button	7-4
<b>Section8 STEP5 Operation on the NS Hardware</b>	
8-1 Operation Procedure	8-1
8-2 Connecting NS Hardware and a Personal Computer	8-2
8-3 Transferring Data	8-3
8-4 Restarting NS Hardware and Personal Computer	8-5
8-5 Executing a Project	8-5
<b>Section9 Ethernet Connection</b>	
9-1 System Configuration	9-1
9-2 Setting FinsGateway	9-2
9-3 Setting an Ethernet Unit	9-6
Setting an IP address	9-6
Setting unit No.	9-7
Setting a node number	9-8
9-4 Setting a PLC	9-9
Creating an I/O table	9-9
Creating a routing table	9-13

TABLE OF CONTENTS

*NS series Tutorial Manual*

9-5 Setting at NS-Designer .....	9-16
9-6 Connecting NS Hardware and a Personal Computer ...	9-20
9-7 Transferring Data .....	9-21

## Section1 Outline of Sample Screen

This manual is intended to familiarize you with the operation of NS-Designer through actual operation. The operational procedures and functions for creating sample screens are explained step by step. In this section, the outline of sample screens is described.

1-1 Screen Configuration .....	1 - 1
1-2 Outline of Each Screen .....	1 - 2

## 1-1 Screen Configuration

The project to be created in this manual consists of the following screens.

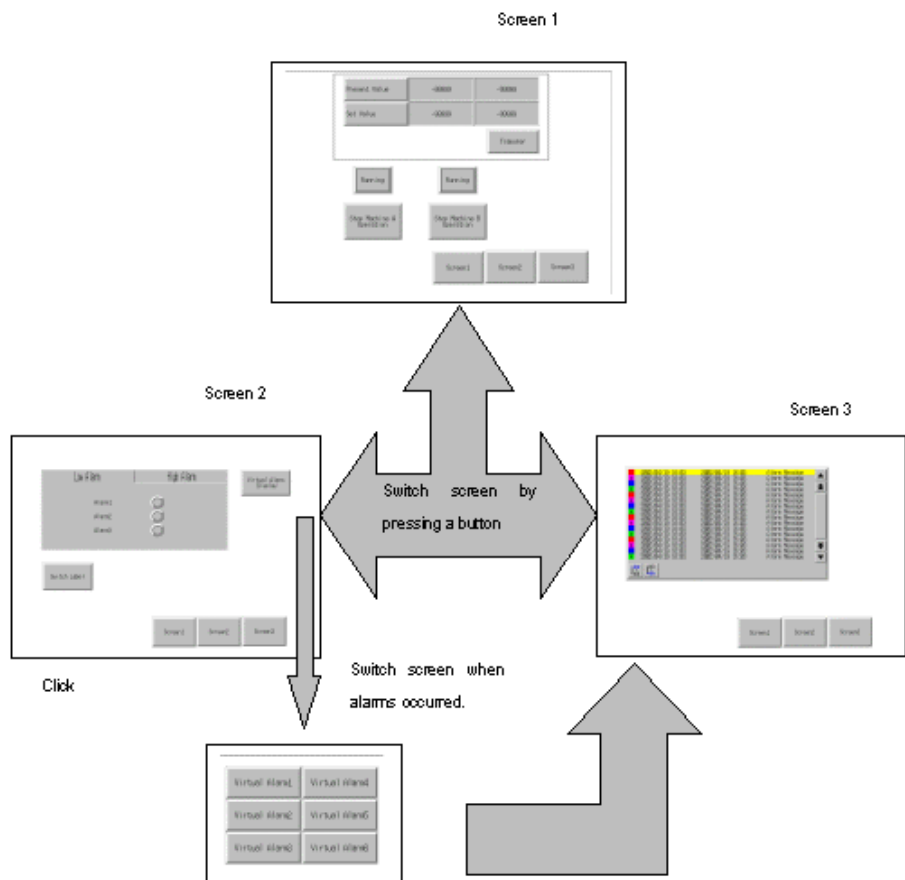

## 1-2 Outline of Each Screen

The outline of each screen is described below.

### Screen1

This is a virtual operation screen. Instruction of operation start/stop and the current value display of PLC are possible. Basic functional objects and fixed objects are used in this screen. For details, refer to 4-1.

### Screen2

This is a virtual alarm screen. When an error (alarm) occurs, correspondent lamp will be turned ON.

You can switch the label to other languages.

A frame object is used in this screen. When using a frame object, you can switch a part of a screen by specifying an address. Here, display of the low alarm list and the high alarm list can be switched. For details, refer to 6-2.

### Screen3

This is a virtual alarm history screen. You can check the alarm histories, which occurred in the past in a list format. When an alarm occurs, this screen will be displayed automatically. For details, refer to 6-3.

### Pop-up window screen

This screen will be displayed when you press the VIRTUAL ALARM OCCUR button on screen2.

This screen has buttons, which cause virtual alarms. For details, refer to 6-4.

## Section2 Operation Flow

The procedures to create sample screens are described in this section.

2-1 Operation Flow .....	2 - 1
--------------------------	-------



## 2-1 Operation Flow

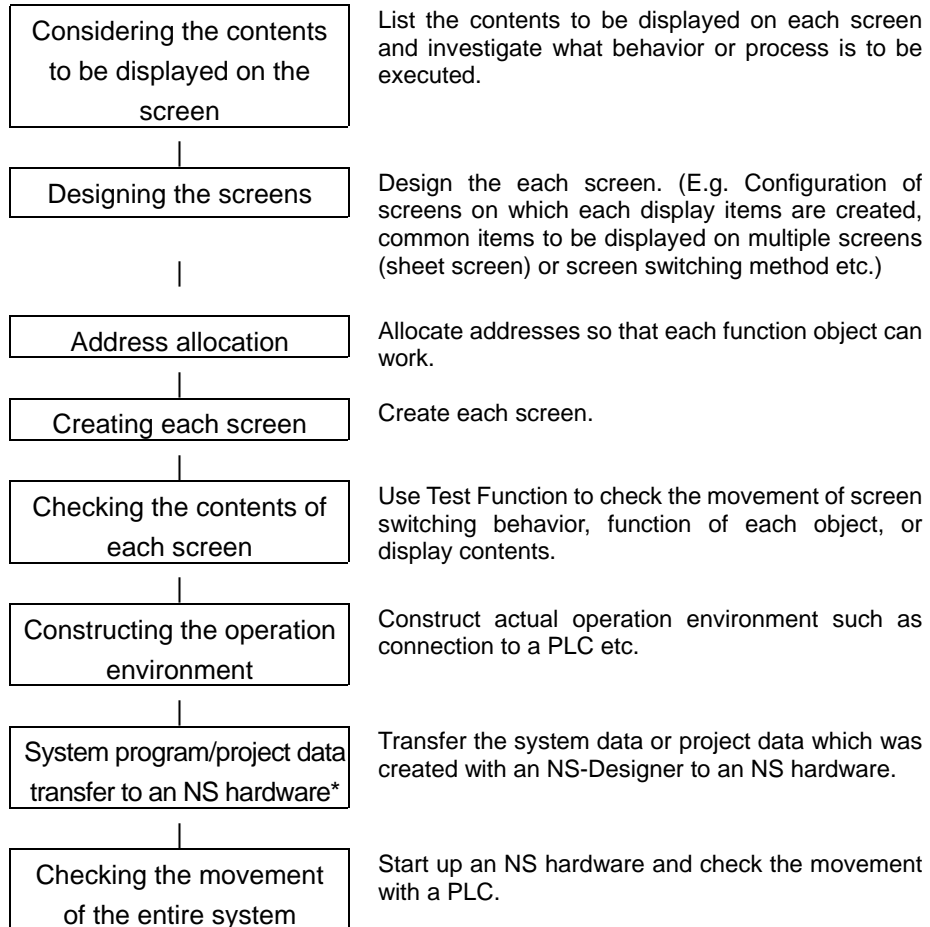

\* Installation of system program is needed only when the system in an NS hardware is corrupted or when it should be replaced.

## Section3 Starting-up and Exiting the NS-Designer

Before creating sample screens, the procedure for starting up and exiting the NS-Designer is described here.

3-1 Starting up the NS-Designer .....	3 - 1
3-2 Exiting the NS-Designer .....	3 - 2

### 3-1 Starting up the NS-Designer

1. Display the desktop screen of Windows NT or Windows 95/98/Me/2000/XP.

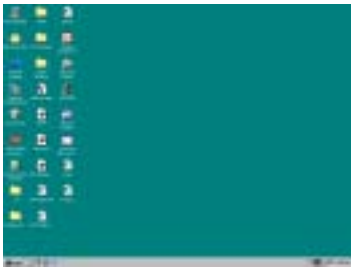

2. Select [Start] – [Programs] – [Omron] – [NS-Designer Ver.x] – [NS-Designer Ver.x].

3. NS-Designer starts up.

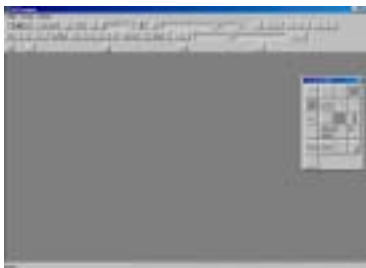

## 3-2 Exiting the NS-Designer

To exit the NS-Designer, use any of the operations shown below.

- In the menu, select [File] – [Exit].
- Click on  button at the upper right corner in the main window.
- Double click the NS-Designer icon displayed at the upper left section in the main window.
- Click the NS-Designer icon displayed at the upper left section in the main window, then select [Close] in the control menu box.
- Press F4 key while pressing down the Alt key.

If the currently opened project data is not saved yet, confirmation dialog will be displayed.

After you exit the NS-Designer, the screen returns to the Windows screen.

## Section4 STEP1 Creating a Simple Screen

This section describes the basic operation of NS-Designer including the procedure to create new project/screen and the procedure to save project data.

4-1	Outline of the Screen to be Created in STEP1 .....	4 - 1
4-2	Creating a New Project .....	4 - 3
4-3	System Setting .....	4 - 7
4-4	Host Registration .....	4 - 8
4-5	Screen Property Setting .....	4 - 9
4-6	Grid Setting .....	4 - 10
4-7	Creating Screen1 .....	4 - 11
4-8	Saving a Screen .....	4 - 20
4-9	Creating Sheet1 .....	4 - 21
4-10	Applying a sheet .....	4 - 24

## 4-1 Outline of the Screen to be Created in STEP1

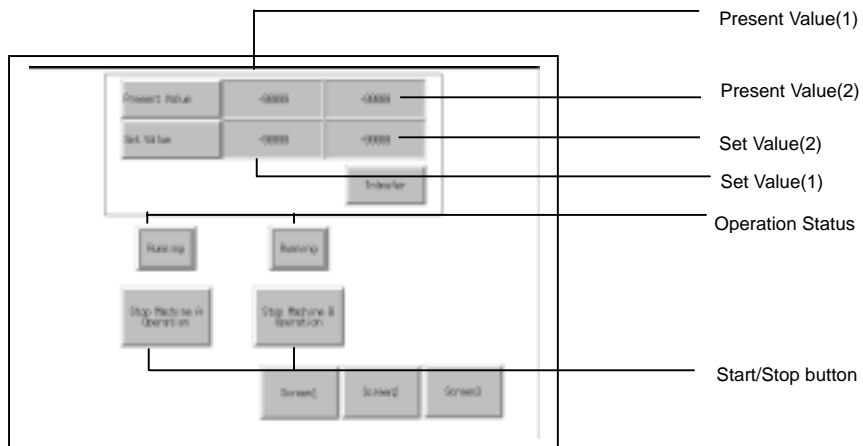

This section describes the outline of screen1 and sheet1.

### Outline of screen1

Outline of screen1 is described below.

#### Function outline

##### 1.Start/Stop button

Each time you press the button, it goes ON and OFF alternately.

##### 2.Operation Status

“RUN” lamp turns ON when the Start/Stop button goes ON, and it turns OFF when the Start/Stop button goes OFF.

##### 3.Set Value (1)/(2) input/display Field

(a) Numeral value is displayed, or input from keypad.

(b) Set value (1) will be calculated and the result is displayed in set value (2). This function is added in STEP4 using macro function.

##### 4.Present value display field (1)/(2)

The value of PLC address is displayed in present value display field (1) and (2).

## Section4 STEP1 Creating a Simple Screen

### NS series Tutorial Manual

#### Outline of sheet1

Sheet1 will be overlapped with other screens. Therefore, sheet1 itself will not be displayed as an independent screen. Sheet1 will be overlapped with screen1, 2 and 3 (screen2 and 3 will be created later).



#### Function outline

##### Screen switch button

When the button is pressed, the screen switches.

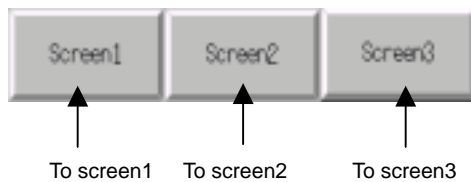

When the sheet1 is overlapped with screen1, the screen will be as follows.



## 4-2 Creating a New Project

Before creating screens, you need to create a project, which stores screens.

1. Create new project.  
Select [File] – [New project].
2. Specify the PT model system version.
  - (1) Select NS12-TS0□(-V1).
  - (2) Select System Ver.4.0
  - (2) Click on [OK] button.



3. Select the screen creating procedure.
  - (1) Select [New Screen].
  - (2) Click on [OK] button.





## Section4 STEP1 Creating a Simple Screen

### NS series Tutorial Manual

4.New screen opens.

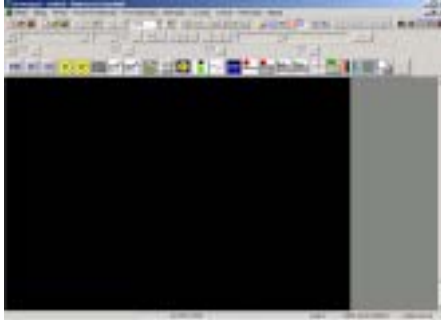

Make a parameter setting of a project.

1. Select - [Settings] - [Project properties].
2. Set a comment for a project.
  - (1) Click on [Title] tab.
  - (2) Input "Tutorial".

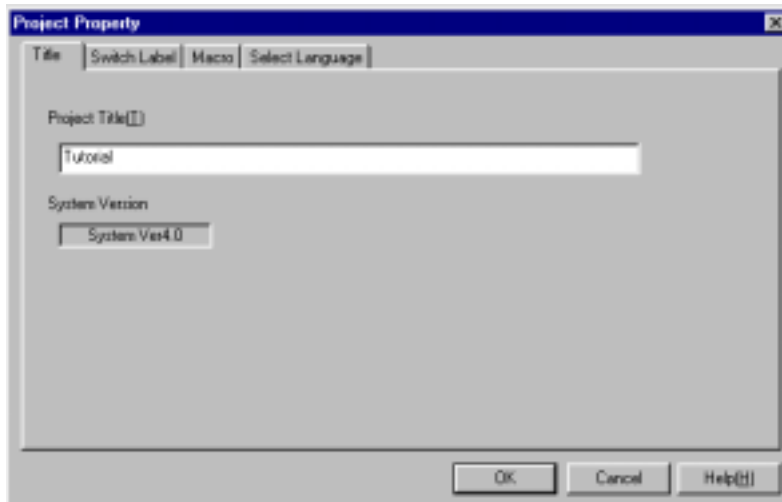

## Section4 STEP1 Creating a Simple Screen

### NS series Tutorial Manual

#### 3. Set a number of labels.

- (1) Click on of [Switch Label] tab.
- (2) Set "2" for [No. of labels].
- (3) Set "English" for [Label name] of [Switch No.0].
- (4) Set "Japanese" for [Label name] of [Switch No.1].

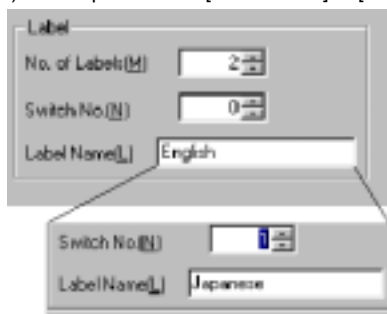

#### 4. Click on [OK] button.

Confirmation dialog will be displayed. Click on "Yes".

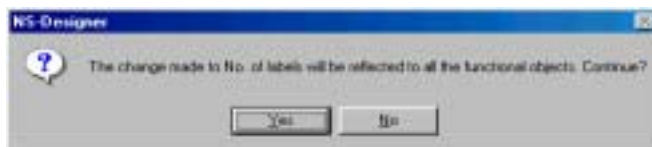

#### 5. Save a project.

Specify a folder and file name.

- (1) Create the folder "Tutorial".
- (2) Input "Project" as a project name.
- (3) Click on [Save] button.



Confirmation dialog will be displayed. Click on [Yes to all] button.

## Section4 STEP1 Creating a Simple Screen

### NS series Tutorial Manual

#### Opening a screen

The screen will be closed when saving a project. Open the screen again. Dialog box to open a screen will be displayed automatically.

##### 1. Select a screen No.

- (1) Click on the screen page number [0000].
- (2) Click on [OK] button.



##### 2. Selected screen opens.

### 4-3 System Setting

The setting here assumes that you are going to use serial port A with NS hardware.

1. Select [Settings]- [System Setting].
2. [System Setting] dialog is displayed.



3. Set as follows.

(For the settings not shown below, use default.)

Tab	Item	Contents
Initial	System Memory	
	\$SB allocation address	\$B1600
	\$SW allocation address	\$W1600

With the default setting, serial port A is used. Use the default setting here.

4. Click on [OK] button.

#### **Reference**

- To use Ethernet, refer to Section9 "Ethernet Connection".

## 4-4 Host Registration

Register a host (PLC name of communication destination).

1. Select [Settings] – [Register Host].
2. Register a host.  
Select the first line and click on [Edit].

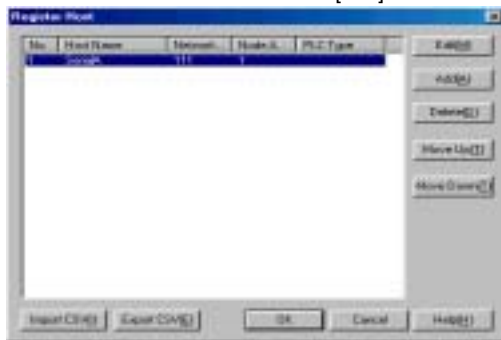

With the default setting, “SerialA” is set. Change the host name.

3. Set as shown below.

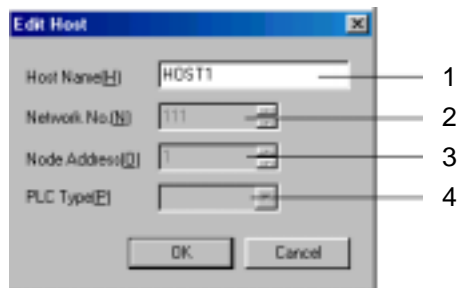

No.	Item	Contents
1	Host Name	HOST1(Default: Serial A)
2	Network No.	111(Fixed*)
3	Node Address	1 (Fixed*)
4	PLC Type	No setting*

\*: To use Serial Port A, setting is not possible.

4. Click on [OK] button and close the [Register Host] dialog.

## 4-5 Screen Property Setting

The screen setting method is described in detail.

1. Select [Settings] – [Screen Properties].
2. Set a title.
  - (1) Select [Title] tab.
  - (2) Input "Screen1".



3. Set a background color.
  - (1) Select [Background/Others] tab.
  - (2) Set "White" (color No: 015).

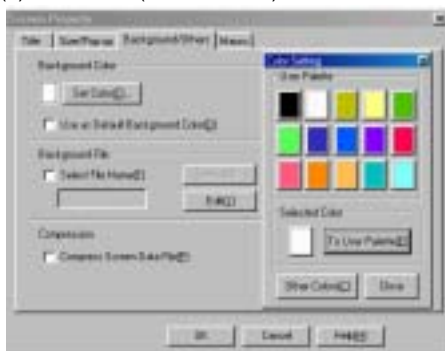

Use the default screen size.

Screen size: 800×600[Default]

4. Click on [OK] button.

## 4-6 Grid Setting

Specify a grid before creating a screen. Once you set a grid, you can move an object at fixed interval. So you do not have to adjust the position of an object minutely.

1. Select [Layout] - [Grid].

2. Specify the grid space.

Set 8 for width and height.



3. Activate grid setting.

Check the [Snap to Grid] box.

To display grid, check ON [Display Grid].

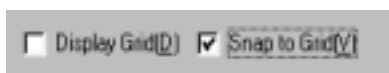

4. Click on [OK] button.

## 4-7 Creating Screen1

The procedures to create objects on the screen and set properties are described.

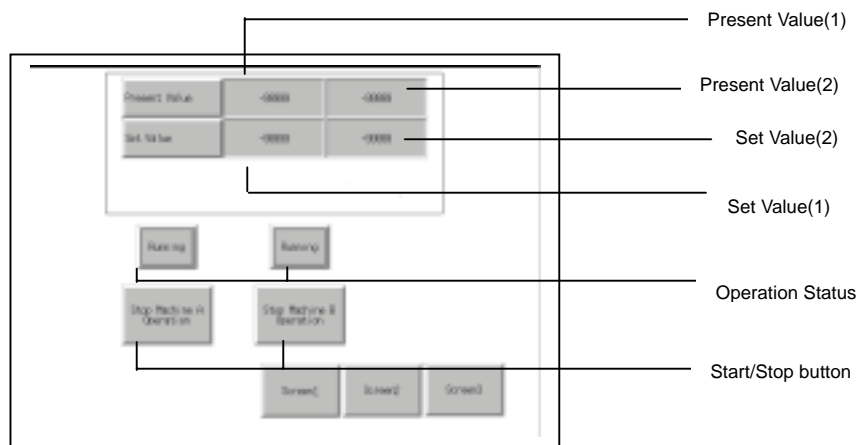

### Creating functional objects

Create "Start/Stop Machine A Operation" button.

1. Click on [ON/OFF Button]  from [Functional Objects] toolbar.

2. Create ON/OFF button on the screen.

- (1) Click on a desired position on the screen with the "+" shaped mouse cursor.
- (2) Drag the cursor until the object becomes to the desired size.

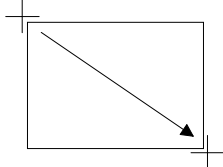

3. Open the property setting dialog box of ON/OFF button.

Place a cursor on the ON/OFF button and double-click on it.

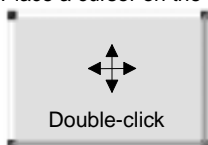



## Section4 STEP1 Creating a Simple Screen

### NS series Tutorial Manual

#### 4. Choose Action Type

Select [Alternate]. When [Alternate] button is pressed, 1 and 0 are written to the specified communication address alternately.

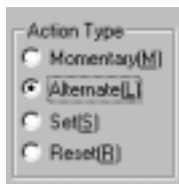

#### 5. Input address from [Address Setting] dialog.

Click on [Set] button.



#### 6. Set address.

Set CIO 00000.00.

(1) Set as shown below.

Host name: HOST1 (Hereafter, select HOST1 to set PLC address.)

Area Type : Select CIO, Bit Addressing

Word : Input "0" using key button

Bit : 0

(2) Click on [OK] button.



#### 7. "HOST1:00000.00" is set in write address input field.



#### 8. Set label for OFF status.

(1) Select [Label] tab.

(2) Input "Start Machine A Operation" as a label.

## Section4 STEP1 Creating a Simple Screen

### NS series Tutorial Manual

#### 9. Set label for ON status.

- (1) Check ON "Switch Labels for Address ON/OFF" box.
- (2) Check ON "Link with write address ON/OFF" box.
- (3) Click on "ON/OFF" button.
- (4) Input "Stop Machine A Operation" as a label.

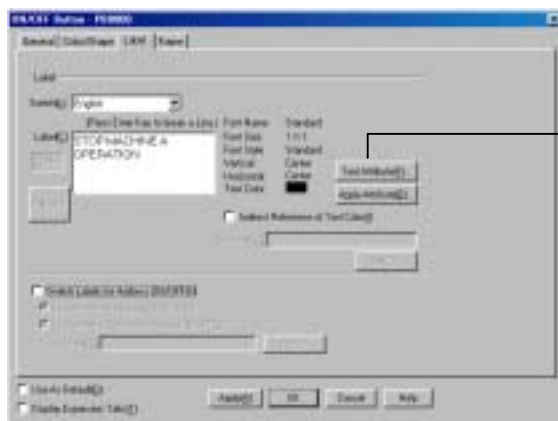

To change the next attribute, click this button. Font size and other setting can be changed.

#### 10. Click on [OK] button.

Create the buttons shown below in the same manner.

\*: The content in ( ) shows an object name to be used.

#### (1) Start/Stop Machine B operation button (ON/OFF button)



Tab	Item	Contents
General	Action type	Alternate
	Write address	HOST1:00000.01
Label	Switch labels for address ON/OFF	Check ON
	Label for OFF	Start operation MachineB
	Label for ON	Stop operation MachineB

Section4 STEP1 Creating a Simple Screen

**NS series Tutorial Manual**

(2) Machine A running (bit lamp)

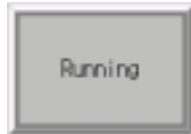

Tab	Item	Contents
General	Lamp type	Double-lined rectangle
	Display address	HOST1:00000.00
Color/Shape	Color1 (Foreground color for OFF)	Grey (Color No: 007)
	Color2 (Foreground color for ON)	Yellow (Color NO: 014)
Label	Label	Running

(3) Machine B running (bit lamp)

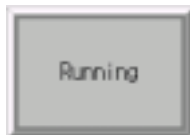

Tab	Item	Contents
General	Lamp type	Double-lined rectangle
	Display address	HOST1:00000.00
Color/Shape	Color1 (Foreground color for OFF)	Grey (Color No: 007)
	Color2 (Foreground color for ON)	Yellow (Color NO: 014)
Label	Label	Running

## Creating functional objects using a table

Create numeral display & input objects collectively (2x2, with 2 labels) using “Table” function.

Present Value	-99999	-99999
Set Value	-99999	-99999

1. Click on [Table]  from [Functional Objects] toolbar.
2. Create a table.
3. Open a property setting dialog of table.  
Double-click on the area specified as a table.

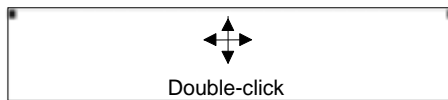

4. Select a functional object from a combo box.  
Select “Numeral display&input”. (See the figure of 5)
5. Set Auto-allocation of communication address.
  - (1) Check ON “Allocate Addresses Automatically” box.
  - (2) Select “Horizontal” for allocate direction.
  - (3) Set “1” for Address Allocation Interval.



## Section4 STEP1 Creating a Simple Screen

### NS series Tutorial Manual

6. Set the number of rows and lines of table.  
Set "2" for Horizontal and Vertical. (see the figure of 7)
7. Set the position of item name.  
Select "Left".

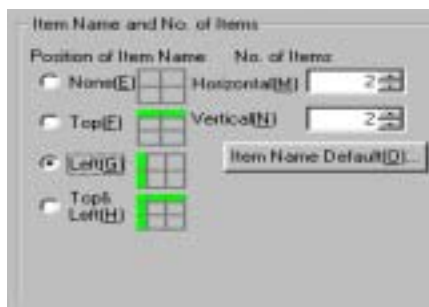

The property setting of a table is finished. Next, set the property setting of numeral display & Input objects, which are displayed in a table collectively.

1. Click on [Functional object default] button in table setting dialog.
2. Set as shown below.

Tab	Item	Contents
General	Numeral display type	
	Display type	Decimal
	Storage type	INT(signed 1 word )
	Format	Integer: 5, Decimal: 0
	Address	HOST1:DM00000 Specify a start address to be allocated.

3. Click on [OK] and close table setting dialog.

## Section4 STEP1 Creating a Simple Screen

### NS series Tutorial Manual

Set the property of each functional object in a table.

To open a property setting dialog of each object, double-click on the object.

Set the property of functional objects in a table as shown below.

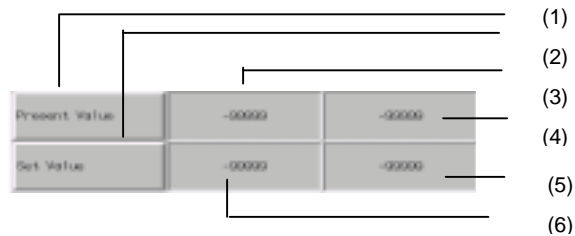

(1) Item : Present value (label)

Tab	Item	Contents
Label	Label	Present value

(2) Item: Set value (label)

Tab	Item	Contents
Label	Label	Set value

(3) Present value1 (numeral display & input)

Check ON "Display expansion tabs" to display "Control flag" tab.

Tab	Item	Contents
Control Flag	Input	Disable

(4) Present value2 (numeral display & input)

Tab	Item	Contents
Control Flag	Input	Disable

(5) Set value1 (numeral display & input)

Tab	Item	Contents
General	Address	PT memory, \$W0

(6) Set value2 (numeral display & input)

Tab	Item	Contents
General	Address	PT memory, \$W1

## Reference

The size of functional objects in a table can be changed by line or row unit.

1. Place a cursor on the vertical/horizontal border of functional objects. The shape of the cursor changes as follows.

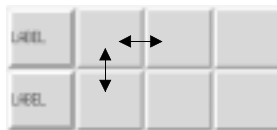

2. Drag the cursor in the indicated direction to modify the size.



It is also possible to change the size of a table. When the table size is changed, the functional objects in a table will be also resized.

1. Place a cursor on the outer frame of a table. The shape of the cursor changes as follows.



2. Drag the cursor in the indicated direction to modify the size.

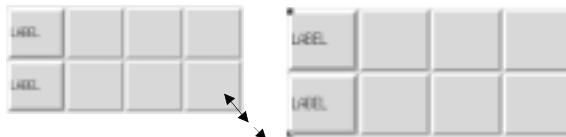

## Creating a fixed object

Create a rectangle which encloses the table.

Primary Value	-0000	-0000
Det. Value	-0000	-0000

1. Click on [Rectangle]  from [Fixed Objects] toolbar.
2. Draw a rectangle.
  - (1) Click on a desired position on the screen with the "+" shaped mouse cursor.

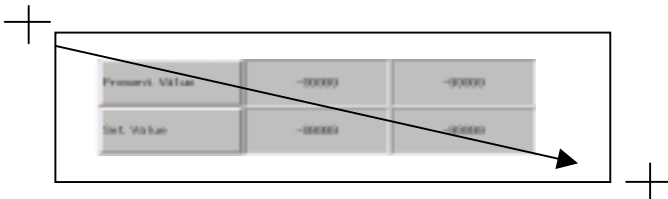

- (2) Drag the cursor until the object becomes to the desired size.
3. While selecting a rectangle, make a right click. Select [Order] – [Send To Back] from pop-up menu.
4. Set a property of rectangle.
  - (1) Place a cursor on a rectangle and double click on it.
  - (2) Set as shown below.

Tab	Item	Contents
Tiling	No tiling	Check ON
Line	Color	Black (Color No: 000)

5. Click on [OK] button.



## 4-8 Saving a Screen

Creation of screen1 is finished. Save screen1.

1. Click on [Save screen]  from [Standard] toolbar.

## 4-9 Creating Sheet1

Create a sheet, which is used to overlap with screen1, 2 and 3.



### Creating new sheet

1. Select [File] – [Open Sheet].
2. Specify a sheet number.  
(1) Select "0000".  
(2) Click on [OK] button.



3. Confirmation dialog is displayed.  
Click on [Yes] button.

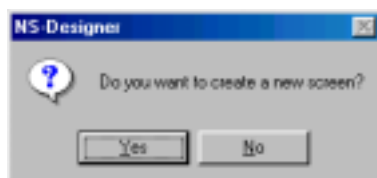

## Section4 STEP1 Creating a Simple Screen

### NS series Tutorial Manual

#### 4. Set a screen property. ([Settings] – [Screen Properties])

(1)Set as shown below.

Tab	Item	Contents
Title	Screen Title	Sheet1
Background/ Others	Background Color	White (Color No: 015)

Use the default screen size.

Screen size: 800x600(Default)

(2)Click on [OK] button.

#### 5. Sheet opens.

## Section4 STEP1 Creating a Simple Screen

### NS series Tutorial Manual

#### Creating an object

Create the following objects on the sheet.



#### (1) Screen switch button to screen1 (command button)

Tab	Item	Contents
General	Function	1.Switch screen 2.Select [Specified screen] 3.Click on [Select] button and choose "0000: Screen1".
Label	Label	Screen1

#### (2) Screen switch button to screen2 (command button)

Tab	Item	Contents
General	Function	1.Switch screen 2.Select [Specified screen] 3.Click on [Select] button and choose "0001".
Label	Label	Screen2

#### (3) Screen switch button to screen3 (command button)

Tab	Item	Contents
General	Function	1.Switch screen 2.Select [Specified screen] 3.Click on [Select] button and choose "0002".
Label	Label	Screen3

#### Saving a sheet

Creation of sheet1 is finished. Save sheet1.

1. Click on [Save Screen]  from [Standard] toolbar.

## 4-10 Applying a Sheet

Apply a sheet to other screens.

1. Select [File] – [Apply Sheet].
2. Apply sheet1 to screen1.
  - (1)Select “0000 Screen1”.
  - (2)Check ON “0” ..... Selection of sheet1
  - (3)Click on [Apply] button.



3. Sheet1 is applied to screen1 and is displayed in a preview window.



4. Apply sheet1 to “0001” (it will be created later as screen2) and “0002” (it will be created later as screen3) in the same manner.
5. Click on [OK] button.

## Section5 STEP2 Debug

This section describes the procedure to debug the project you have created in STEP1 on a personal computer.

5-1 Test Function .....	5 - 1
5-2 Test Tool .....	5 - 3
5-3 Exiting a Test .....	5 - 5

## 5-1 Test Function

NS-Designer has a test function. If you use this function, you can check the movement of project data on a personal computer without connecting a PLC. Check the movement by operating registered functional objects with a test function.

### Starting a test

Before executing a test, set the condition for start-up of a test.

1. Select screen1 from [Window] menu to bring this screen to front.
2. Select [Tools] - [Test].
3. Confirmation dialog to save project data is displayed. Press [Yes] button.
4. Set the condition for start-up of a test.  
Check ON "Start test from the current screen". (Screen1 will be displayed in a test screen.)

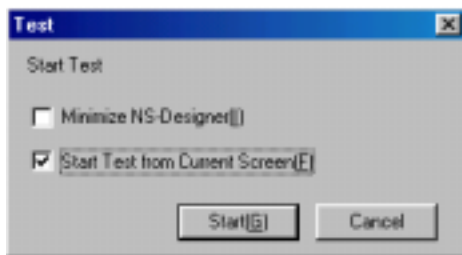

5. Start a test.  
Click on [Start] button.

## Executing a test

Test screen and test tool are started up.

1. Test screen is displayed in a window.  
(Default size: 800dot×600dot)

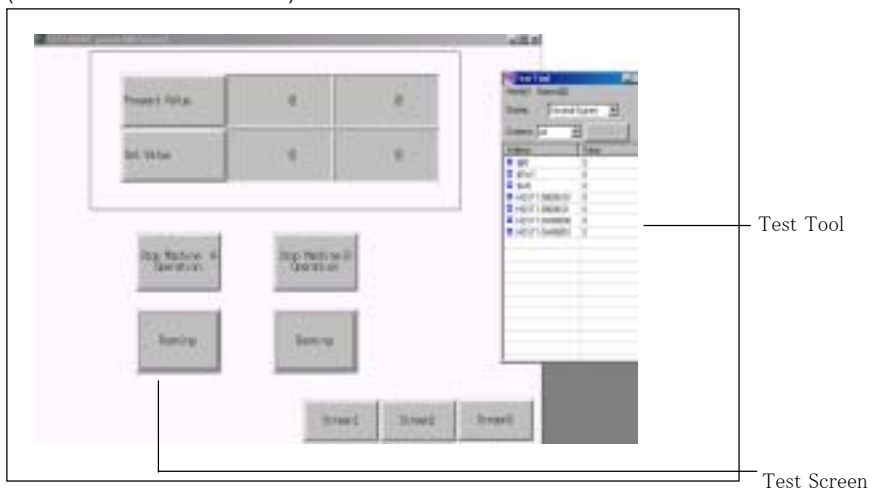

2. Check the movement of objects by clicking a button or input numeral value to a numeral display&input.

### **Reference**

How to switch test screen to a screen with a title bar and menu bar:

Double-click on a screen where no object is registered, screen display style will be changed to [With title bar and menu bar]->[With menu bar]->[With Title bar]->[Full screen].

When a test tool is displayed at the center of a screen, confirmation dialog to exit a test may be hidden by a test tool. When a confirmation dialog is not found, change the display position of a test tool to check if the dialog box is hidden.



## 5-2 Test Tool

Check the movement of functional objects by changing the value of address with a test tool.

Check the online movement of functional objects by changing the address to ON and OFF or writing a value.

1. Select the address you want to change value and double-click on it.  
Select HOST1: 00000.00 and double-click on it.

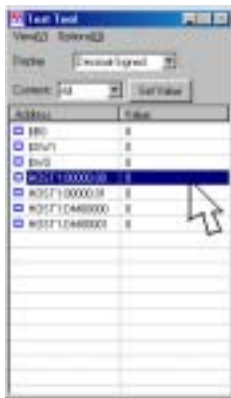

Double-click

2. Turn ON HOST1:00000.00.  
Click on [SET] button.

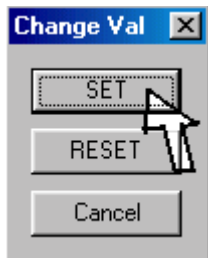

Section5 STEP2 Debug

**NS series Tutorial Manual**

3. When the HOST1:00000.00 is turned ON, the display of a button changes as follows. At the same time, the correspondednt lamp is lit.



Click on [RESET] button in [Change Val] dialog.



5. Write value to \$W0.  
(1) Select \$W0 and double-click on it.  
(2) Input "123" to [Change Value] dialog.  
(3) Click on [OK] button.



6. "123" is displayed in Set Value1.

Present Value	8	8
Set Value	123	8

## 5-3 Exiting a Test

Exit a test.

1. Click on  button on a title bar.
2. Confirmation dialog to exit a test is displayed.  
Click on [Yes] button.

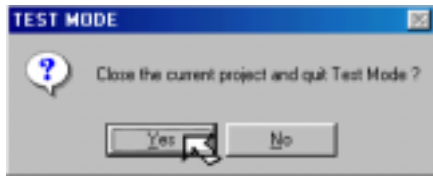

### ***Reference***

Each time you double-click on a screen where no object is registered, window style changes. When a menu bar is displayed, you can exit a test by selecting [Quit] from [File] menu.

1. To display a menu bar, make a double-click three times. Window style changes to [No title bar]->[Full screen]->[With title bar and menu bar].



2. Display a menu bar and select [Quit] from [File] menu.
3. Confirmation dialog to exit a test is displayed. Click on [Yes] button

## Section6 STEP3 Useful Functions

This section describes the useful functions of NS-Designer. It is assumed that you have basic knowledge of objects and the operation method of NS-Designer.

6-1 Outline of Screens to be Created in STEP3 .....	6 - 1
6-2 Creating Screen2 .....	6 - 5
6-3 Creating Screen3 .....	6 - 22
6-4 Creating a Pop-up Window Screen .....	6 - 23

## 6-1 Outline of Screens to be Created in STEP3

The outline of a screen2, 3 and a pop-up window screen which will be created in STEP3 is shown below.

### Outline of screen2

Outline of screen2 is shown below.

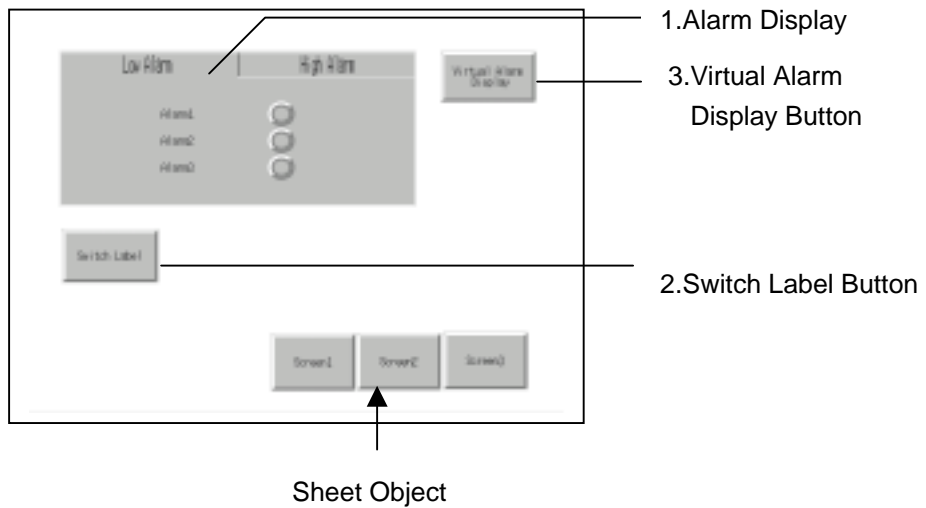

### **Reference**

- If you switch frame page frequently, update of communication will be delayed.

## Function outline

### 1. Alarm display

Press the tab area to switch display.



#### Low alarm display

When you press any of the virtual alarm occur button1-3 in a pop-up window screen, correspondent alarm lamp goes ON. When the alarm is cancelled, correspondent lamp goes OFF.

#### High alarm display

When you press any of the virtual alarm occur button4-6 in a pop-up window screen, correspondent alarm lamp goes ON. When the alarm is cancelled, correspondent lamp goes OFF.

### 2. Switch label button

When you press this button, a pop-up menu to switch the language of label (English/Japanese) is displayed. Selected label type is applied.



### 3. Virtual alarm display button

When you press this button, a pop-up window screen which has virtual alarm display buttons is displayed.

### Outline of screen3

Outline of screen3 is shown below.

When an alarm occurs, this screen will be displayed automatically.

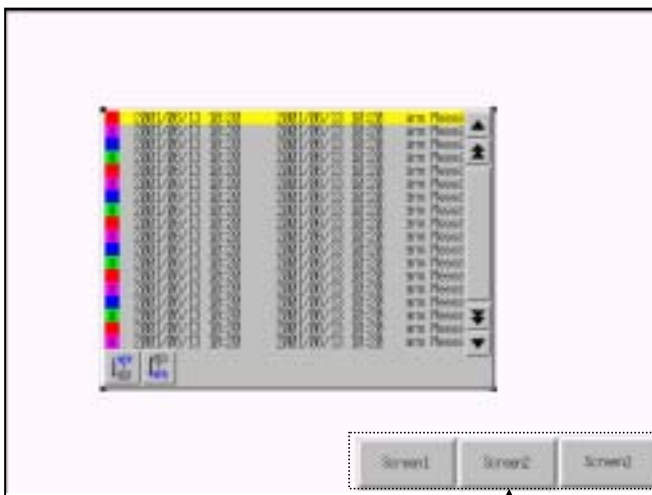

Sheet Object

### Function Outline

#### 1. Virtual alarm occurrence history

Virtual alarm history which is occurred/cancelled on a pop-up window screen is displayed.

## Outline of a pop-up screen

Outline of a pop-up screen is shown below.

This screen is displayed when you press virtual alarm display button in screen2.

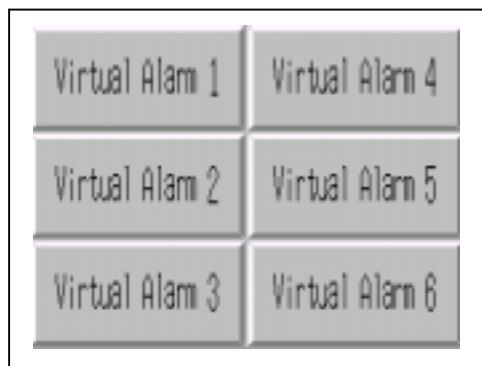

## Function outline

### 1. Virtual alarm occurrence button 1 to 6

Each time you press the button, each virtual alarm will be ON and OFF alternately.



## 6-2 Creating Screen2

### Creating a new screen

1. Select [New screen]  from [Standard] toolbar.
2. Set the screen property as shown below.

Tab	Item	Contents
Title	Screen Title	Screen2
Background/ Others	Background color	White (Color No: 015)

Use the default screen size.  
Screen size: 800x600(Default)

### Alarm/Event setting

Set the contents to be displayed as an alarm.

1. Select [Settings] - [Alarm/Event].
2. Register an alarm.  
Click on [Add] button.



3. Input alarm message.  
Input "Alarm 1 occur" in [Message].

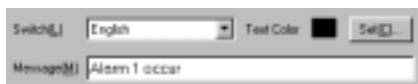

Section6 STEP3 Useful Functions

**NS series Tutorial Manual**

4. Select display type.  
Choose [Low alarm] for [Display type].



5. Set address.  
Set "HOST1:00001.00" as an address.  
When HOST1:00001.00 goes ON, the alarm is detected.



6. Set the screen to be displayed when an alarm occurs.
  - (1) Check ON "Switch screen when address ON".
  - (2) Click on [Set (3)] button and select "0002" screen.



7. Click on [OK] button.

Set the following alarms in the same manner.

No.	Message	Display type	Address	Switch screen when address ON	Switch screen No.
2	Alarm2 occur	Low alarm	HOST1:00001.01	Check ON	0002
3	Alarm3 occur	Low alarm	HOST1:00001.02	Check ON	0002
4	Alarm4 occur	High alarm	HOST1:00001.03	Check ON	0002
5	Alarm5 occur	High alarm	HOST1:00001.04	Check ON	0002
6	Alarm6 occur	High alarm	HOST1:00001.05	Check ON	0002

## Section6 STEP3 Useful Functions

### *NS series Tutorial Manual*

8. With the default setting, it is not possible to switch to other screen from the specified screen unless the alarm is cancelled.

Change the setting so that the screen switches only the moment when an alarm occurred.

Click on [Parameter] button.

9. Click "Rise trigger detection" and press [OK] button.



10. Click on [OK] in [Alarm/Event Setting] dialog.

## Creating a frame object

Create a frame object to switch the low alarm screen and the high alarm screen.  
With a frame object, specified area can be switched.

1. Create a frame object.

Click on [Frame]  from [Functional objects] toolbar and place it on the screen.

2. Set a frame property.

While selecting a frame, choose [Setting] - [Object Properties].

3. Set the number of frame pages.

Set 2 for [No. of Frames].

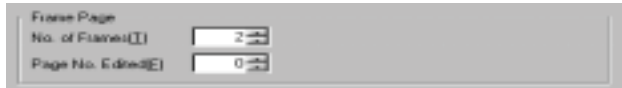

4. Set the address.

Set "\$W2" for [Frame Page Ref. ]. Frame page will be switched in accordance with the change of value in \$W2.



5. Set a tab which is used to switch a frame page on NS hardware.

(1) Check ON "Attach a Tab to a Frame".

(2) Set as shown below.

Tab Color: Gray (Color No: 007)

Tab Position: Up

Tab Height: 2

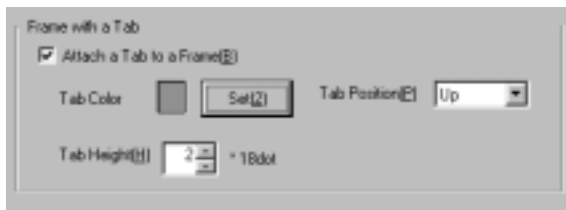

Section6 STEP3 Useful Functions

*NS series Tutorial Manual*

6. Click on [OK] button.

7. A frame is created.





## Editing a frame page

To create objects inside a frame, enter the frame edit mode.

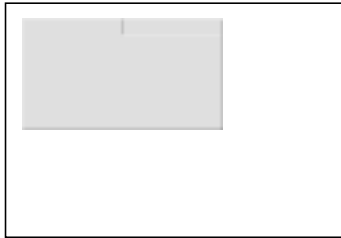
1. Double-click inside a frame.
2. Frame enters the edit mode, objects outside a frame will be invisible.



3. Click on [Previous frame page] or  [Next frame page] to  switch the frame page to be edited.
4. To return to the normal edit mode, click the area outside of a frame.

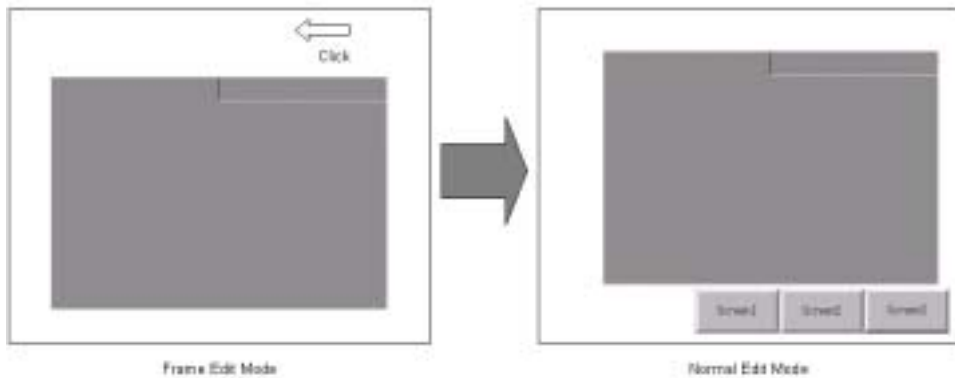

## Creating a frame tab name

Create a title of frame tab using a text object. If a text is created in frame edit mode, tab titles which are not in active statuses will be invisible on NS hardware. Therefore, create tab titles in normal edit mode.

1. Click on [Text] from toolbar and paste a label so that it overlaps with the frame tab position.

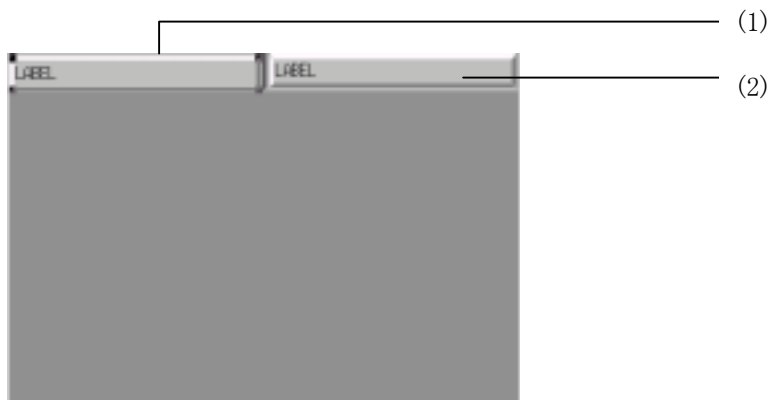

## Reference

When a message to inform you that you can not create an object overlapping on the other objects is displayed, cancel this restriction by following the procedure below.

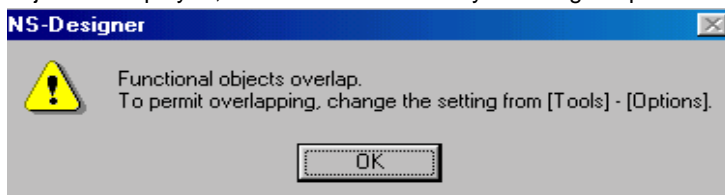

1. Select [Options] from [Tools] menu.
2. Unmark the check box for "Prohibit functional objects from overlapping" in [Edit/Disp] tab.

Section6 STEP3 Useful Functions

**NS series Tutorial Manual**

2. Set the property of each text.

Double-click on the each text to display property setting dialog. Set each tab as follows.

(1) Low alarm display (Text)

Tab	Item	Contents
Background	Tile background	Check OFF
Label	Label	
	English	LOW ALARM
	Japanese	Keido alarm hyouji After setting English label, select "Japanese" from [Switch] combo box in [label] tab and input label. 
Frame	Three-dimensional Frame	Check OFF
	Draw Border	Check OFF

(2) High alarm display (Text)

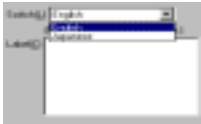
Tab	Item	Contents
Background	Tile background	Check OFF
Label	Label	
	English	HIGH ALARM
	Japanese	Judo alarm hyouji After setting English label, select "Japanese" from [Switch] combo box in [label] tab and input label. 
Frame	Three-dimensional Frame	Check OFF
	Draw Border	Check OFF



## Creating function objects on each frame

Create functional objects on each frame.

### Low alarm display



1. Enter the frame edit mode.  
Double-click on a frame.
2. Display low alarm display (frame page No: 0).
3. Paste a table object.  
Click on [Table]  from [Functional Objects] toolbar and place a table object.

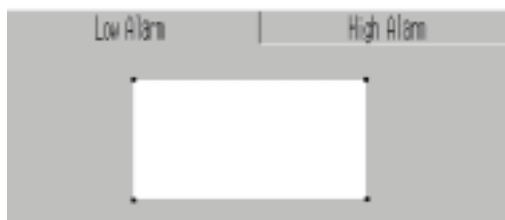

Section6 STEP3 Useful Functions

*NS series Tutorial Manual*

4. Set the table property as shown below.

Item	Contents
Table type	Bit lamp
Allocate Addresses Automatically	Check ON
Direction	Vertical
Address Allocation Interval	1
Position of item name	Left
No. of items	
Horizontal	1
Vertical	3

5. Click on [Functional object default] button and set as shown below.

Tab	Item	Contents
General	Display address	HOST1:00001.00
	Lamp type	Double-lined circle

6. Click on [OK] button to close [Bit lamp] dialog.
7. Click on [OK] button to close [Table setting] dialog.
8. Set the item name (text) of a table as shown below.  
 Double-click on an object to set each property.  
 (Settings not shown below do not have to be changed.)

- (1) Alarm1

Tab	Item	Contents
label	English	ALARM 1
	Text attribute	
	Horizontal position	Center
	Japanese	Ala-mu 1
	Text attribute	
	Vertical position	Center
Background	Tile background	Check OFF
Frame	Three-dimensional frame	Check OFF
	Draw Border	Check OFF

Section6 STEP3 Useful Functions

*NS series Tutorial Manual*

(2) Alarm2

Tab	Item	Contents
label	English	ALARM 2
	Text attribute	
	Horizontal position	Center
	Japanese	Ala-mu 2
	Text attribute	
	Horizontal position	Center
Background	Tile background	Check OFF
Frame	Three-dimensional frame	Check OFF
	Draw Border	Check OFF

(3) Alarm3

Tab	Item	Contents
label	English	ALARM 3
	Text attribute	
	Horizontal position	Center
	Japanese	Ala-mu 3
	Text attribute	
	Horizontal position	Center
Background	Tile background	Check OFF
Frame	Three-dimensional frame	Check OFF
	Draw Border	Check OFF

**Reference**

You can apply text attributes (font name, size, colors etc.) to other label. When you click on [Apply attribute] button, [Apply attribute] dialog is displayed. Check ON the attributes to be applied and click on [OK] button.

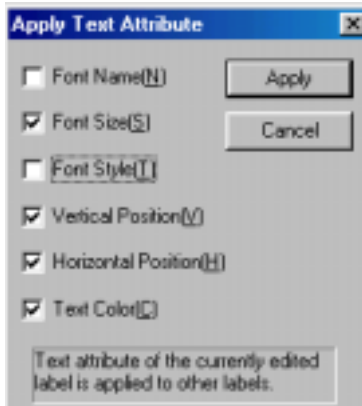

Right after you crate a table, the size of each functional objects inside a table is automatically adjusted so that they will be the same size. Therefore, the bit lamps may be an oval shape depending on the table size. If you want to change it to perfect circle shape, place a cursor on the vertical/horizontal side of bit lamps and drag it.

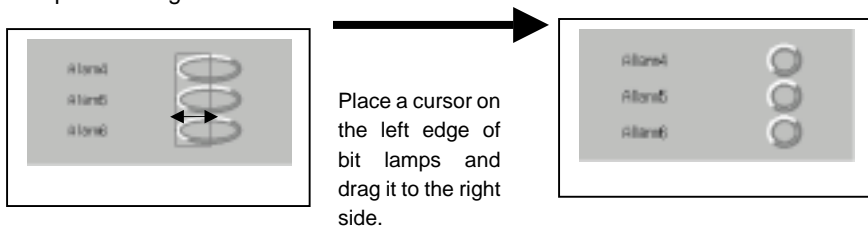

Place a cursor on the left edge of bit lamps and drag it to the right side.

For details of changing a table size, refer to P4-18.

### High alarm display

Reuse the table object which is created in low alarm display page using copy function and offset address function.

The operation procedure and setting contents are shown below.



1. After entering the frame edit mode, select a table in low alarm display page by dragging around the table area.
2. Select [Copy] from [Edit] menu.
3. Click on [Next frame page]  from [operation] toolbar to switch to high alarm display page.
4. Select [Offset Paste] from [Edit] menu.

Section6 STEP3 Useful Functions

*NS series Tutorial Manual*

5. Input "3" for [Offset] and click on [OK].

Addresses from HOST1:00001.03 to HOST1:00001.05 are allocated to pasted bit lamps.



6. Set the item name (Text) of a table as shown below.

(Settings not shown below do not have to be changed.)

It is also possible to set the labels of multiple functional objects collectively.  
For details, refer to "MEMO".

(1) Alarm1

Tab	Item	Contents
Label	Label	
	English	ALARM 4
	Japanese	Ala-mu 4

(2) Alarm2

Tab	Item	Contents
Label	Label	
	English	ALARM 5
	Japanese	Ala-mu 5

(3) Alarm3

Tab	Item	Contents
Label	Label	
	English	ALARM 6
	Japanese	Ala-mu 6

## **Reference**

How to set the labels of multiple functional objects?

It is possible to set the label collectively if the selected object type is the same. Addresses and comments can be also edited.

E.g. The procedure to set labels of high alarm display collectively.

1. Enter the frame edit mode and select the item name (Text) at the top.
2. Select [Edit] – [Select all] – [Same functional object type].
3. Select [Settings] – [Change Settings at Once].
4. [Change Settings at Once] dialog is displayed.
5. Double-click on each cell and input label.
6. When the setting is finished, click on [OK] button.

For details of the setting, refer to NS-Designer operation manual “5-10 Setting multiple functional objects”.

## **Creating switch label button**

Create a word button which changes the label from English to Japanese, or from Japanese to English.

The label No. currently used is stored in system memory \$SW10.

When \$SW10 is 0, English label is displayed, and when it is 1, Japanese label is displayed.

Section6 STEP3 Useful Functions

*NS series Tutorial Manual*

Word button

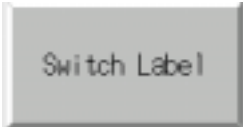

Tab	Item	Contents												
General	Action Type	Select "Display Pop-up Menu".												
	Pop-up menu	<p>(1) Click on [Edit Menu] button.                      (2) [Pop-up Menu List] dialog is displayed.                      (3) Click on [Add] button and set as follows.</p>  <table border="1" data-bbox="817 1039 1146 1136"> <thead> <tr> <th>Menu Name</th> <th>Set Value</th> </tr> </thead> <tbody> <tr> <td>English</td> <td>0</td> </tr> <tr> <td>Japanese</td> <td>1</td> </tr> </tbody> </table> <p>(4) Create a pop-up menu used when label is Japanese.                      Select Japanese from [Switch] combo box.                      (5) Select a line and click on [Edit] button. Set as follows.</p> <table border="1" data-bbox="834 1356 1138 1452"> <thead> <tr> <th>Menu Name</th> <th>Set Value</th> </tr> </thead> <tbody> <tr> <td>Eigo</td> <td>0</td> </tr> <tr> <td>Nihongo</td> <td>1</td> </tr> </tbody> </table>	Menu Name	Set Value	English	0	Japanese	1	Menu Name	Set Value	Eigo	0	Nihongo	1
	Menu Name	Set Value												
English	0													
Japanese	1													
Menu Name	Set Value													
Eigo	0													
Nihongo	1													
Address (Write address)	\$SW10													
Label	Label													
	English	Language Change												
	Japanese	Meiban kirikae												



## Section6 STEP3 Useful Functions

### *NS series Tutorial Manual*

Set the virtual alarm display button as shown below.

Virtual alarm display button (command button)



Tab	Item	Contents
General	Function	1. Switch screen 2. Select "To specified screen". 3. Click on [OK] button and specify "0003".
Label	Label	
	English	Virtual Alarm Display
	Japanese	Kasou alarm display

### 6-3 Creating Screen3

Create a new screen and set the property as shown below.

Tab	Item	Contents
Title	Screen title	Screen3
Background/Others	Background color	White (Color No: 015)

Use the default screen size.  
Screen size: 800x600(Default)

#### Creating an object

Create the following object on screen3.

Alarm history (Alarm/Event summary &history)

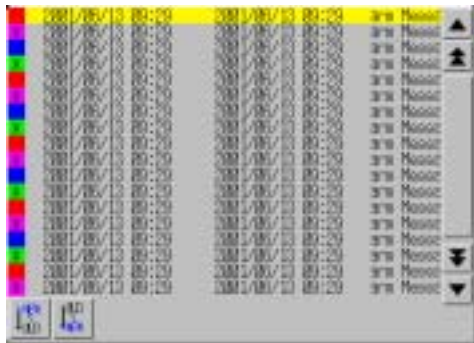

Tab	Item	Contents
General	Display data	Alarm history
	Date &Time Display Format	Check ON
	Date	yyyy/mm/dd
	Time	hh:mm
Icon	Icons	
	From new date &time	Check ON
	From old date &time	Check ON
	Icon size	
	Width	44
	Height	44

## 6-4 Creating a Pop-up Window Screen

Create a new screen.

To create a pop-up window screen which is displayed on the other screen, set the screen properties as follows.

Tab	Item	Contents
Title	Screen title	Pop-up window screen
Size/Pop-up	Screen size	Width: 320, Height: 240
	Use as pop-up screen	Check ON
	Pop-up Screen Display Position	Bottom Left of Screen
Background/Others	Background color	White (Color No: 015)

### Creating an object

Create an object shown below on a pop-up window screen.

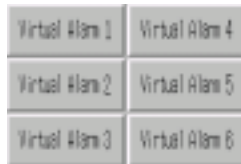

Virtual alarm occur button from 1 to 6.

1. Use Table function to create them collectively.
2. Set the table property as follows.

Item	Contents
Table type	ON/OFF button
Allocate Addresses Automatically	Check ON
Direction	Vertical
Address Allocation Interval	1
Position of Item name	None
No. of items	
Horizontal	2
Vertical	3

Section6 STEP3 Useful Functions

*NS series Tutorial Manual*

3. Click on [Function object default] button and set as follows.

Tab	Item	Contents
General	Action Type	Alternate
	Write address	HOST1:00001.00

4. Click on [OK] button and close [ON/OFF button] dialog.

5. Press [OK] button and close [Table setting] dialog.

6. Set each button as shown below.

(Settings not shown below do not have to be changed.)

- (1) Virtual alarm1 occur button

Tab	Item	Contents
Label	Label	Virtual alarm1

- (2) Virtual alarm2 occur button.

Tab	Item	Contents
Label	Label	Virtual alarm2

- (3) Virtual alarm3 occur button

Tab	Item	Contents
Label	Label	Virtual alarm3

- (4) Virtual alarm4 occur button

Tab	Item	Contents
Label	Label	Virtual alarm4

- (5) Virtual alarm5 occur button

Tab	Item	Contents
Label	Label	Virtual alarm5

- (6) Virtual alarm6 occur button

Tab	Item	Contents
Label	Label	Virtual alarm6

The creation of a pop-up window screen is finished, save a screen.

## Section7 STEP4 Creating Macro

In this section, the procedure to create a sample which uses macro function is described. With a macro function, user's original program can be added to a project/functional objects/screen.

7-1 Outline of Sample .....	7 - 1
7-2 Registering a Macro .....	7 - 2

## 7-1 Outline of Sample

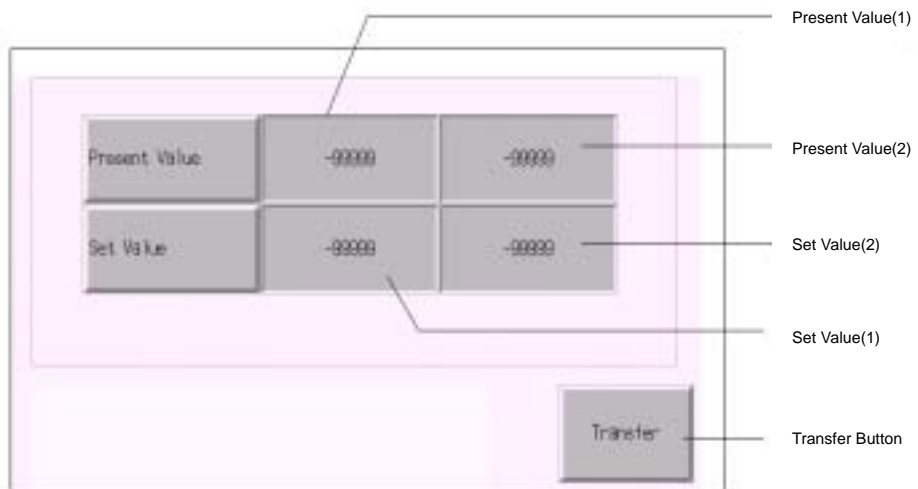

### Screen1

Add a macro function to the object on screen1 which was created in Section4 STEP1.

### Function Outline

#### 1. Set value1

Add a macro function which sets the calculation result of set value1 to a set value2.

#### 2. Transfer button

Add a function to transfer the set value1 and set value2 to PLC addresses. Transmitted results will be displayed at present value1 and present value2.

## 7-2 Registering a Macro

The actual operations for registering and setting a macro function are described.

### Registering a macro for set value1

1. Open the property setting dialog of set value1.
2. Check ON “Display expansion tabs”.
3. Select [Macro] tab.
4. Choose the execution condition.  
Check ON “When Changing Numeral”.



5. Edit a macro.  
Click on [Edit macro] button.
6. Edit macro dialog is displayed.

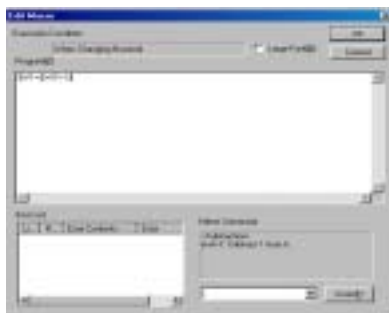

7. Input the description shown below in [program] field.

```
$W1=$W0*10+1;  
'The value of $W0 (set value1) is multiplied by 10 and 1 is added. The result is set to  
$W1 (set value2).
```

The description after "" is a comment. It is possible to omit this. In case you include this, however, be sure to input this within 1 line. If the description is interrupted by a return key, the description after it will not be regarded as a comment (error occurs).

8. Click on [OK] button to close the property.



## Registering a macro for a transfer button

1. Create ON/OFF button and set the property as shown below.

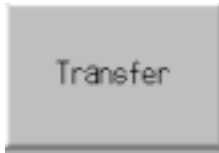

Tab	Item	Contents
General	Action Type	Momentary
Label	Label	Transfer

2. Register a macro.

Choose "Touch ON timing" for execution condition and input the description shown below in edit macro dialog.

```
WRITECMEM([HOST1:DM00000], $W0, 2);
```

'The value \$W0, \$W1 is written to DM00000, DM00001 each.

The creation of macro function sample is finished. Save a screen and perform a test.

### **Reference**

In test mode, the behavior will be as follows.

If you input 10 to set value1, 101 (=10\*10+1) is automatically set to set value2.

Then, when you click on the Transfer button, 10, 101 are input to present value1,2 each (the value of set value1,2 is written to present value1,2).

Present Value	10	101
Set Value	10	101

## Section8 STEP5 Operation on the NS Hardware

This section describes the procedure to transmit the created data to NS hardware to operate it.

Here, the data transfer procedure using RS-232C is described.

For details of the data transfer procedure using Ethernet, refer to section9.

8-1 Operation Procedure .....	8 - 1
8-2 Connecting NS Hardware and a Personal Computer ...	8 - 2
8-3 Transferring Data .....	8 - 3
8-4 Restarting NS Hardware and Connecting to PLC .....	8 - 5
8-5 Executing a Project .....	8 - 5

## 8-1 Operation Procedure

The procedures to transmit the created data to NS hardware and the operation of NS hardware after transmission are described.

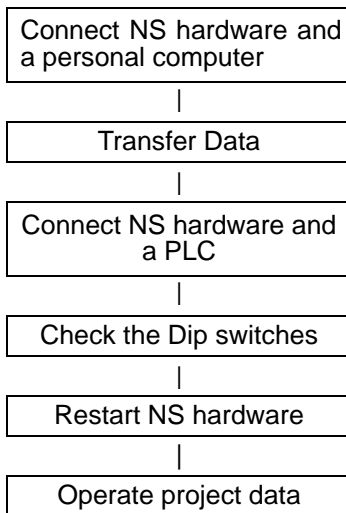

**NOTE**

Before restarting NS hardware, please be sure to check the setting of Dip switches. Depending on the setting, data transfer may be executed from a memory card. Set the Dip switches so that the data transfer is not executed. For details, refer to set up manual "3-5 Using a memory card".

## 8-2 Connecting NS Hardware and a Personal Computer

To transfer the data, connect a personal computer (NS-Designer) and NS hardware using RS-232C cable.

Connect a cable at serial port B on NS hardware side.

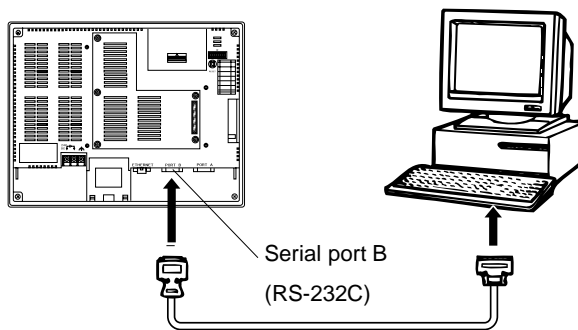

### **Reference**

For details of the communication cable (RS-232C), refer to set up manual "Section2 Preparation before connection" and "Appendix5 Creating a cable connected to a personal computer".

## 8-3 Transferring Data

Transfer the project data “Project” which you created with an NS-Designer to NS hardware.

1. Select [Select project] under [Download Project].
2. Select the project to be transferred.  
Select “Project” after clicking [Select Project] button.
3. Set communication method.  
(1) Click on [Comms. Method] button.  
(2) Set “Serial: COM1” as a communication method.



(3) Click on [Connect] button.

4. Select the data to be transferred.  
Check ON “Select all”.
5. When you click on  button, [Confirmation] dialog is displayed. Data transfer starts after you click on [Start] button.

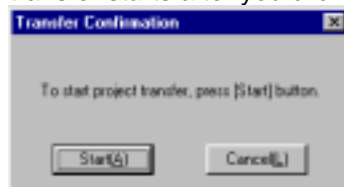

### **Reference**

Data transfer program is an individual application. It can be also started without starting up the NS-Designer.

To start up only the Transfer program, click on [Start] button of Windows and select [Programs] – [Omron] – [[NS-Designer] - [Transfer Tool].

When data transfer is not possible, check the following points.

- Is the cable connected correctly?
- Is the power for NS hardware ON? Check if the starting message which is displayed immediately after turning the power ON is shown?

## 8-4 Restarting NS Hardware and Connecting to PLC

1. When the data transfer is completed, the screen shown below is displayed.



2. NS hardware should be reset after transferring data. Click on [Yes] button in the message dialog shown below which is displayed on a personal computer after data transfer.

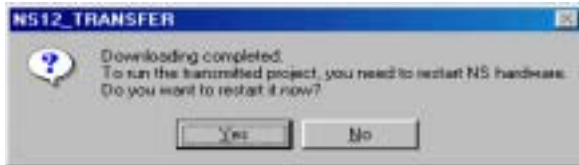

3. Connect PLC and NS hardware. Connect a cable to serial port A at the NS hardware side.

## 8-5 Executing a Project

The project "Project" will be executed after turning ON the power for NS hardware.

The created screen will be displayed in 10 seconds.

## Section9 Ethernet Connection

This section describes the procedure to connect NS hardware and a PLC using Ethernet.

9-1 System Configuration .....	9 - 1
9-2 Setting FinsGateway .....	9 - 2
9-3 Setting an Ethernet Unit .....	9 - 6
9-4 Setting a PLC .....	9 - 9
9-5 Setting at NS-Designer .....	9 - 16
9-6 Conneting NS Hardware and a Personal Computer .....	9 - 20
9-7 Transferring data .....	9 - 21



## 9-1 System Configuration

System configuration is as shown below. One NS hardware is connected to two PLCs using Ethernet.

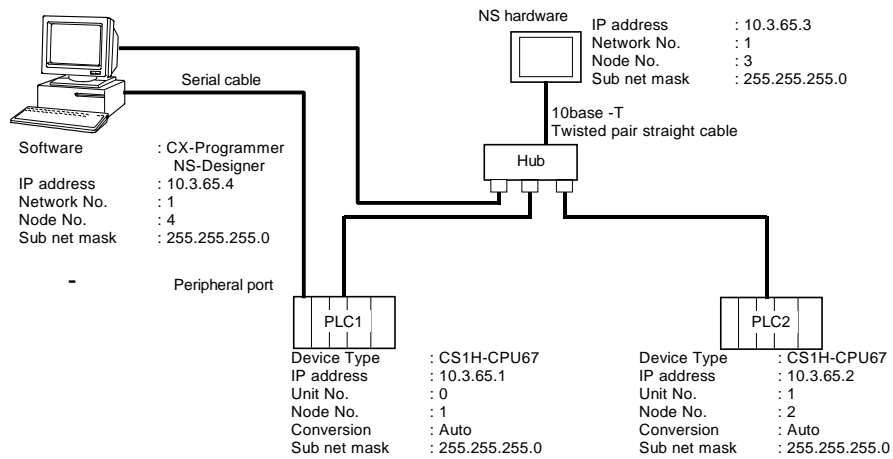

Item	Setting	Page
Ethernet unit	IP address	9-6
	Unit No.	9-7
	Node No.	9-8
PLC	I/O table	9-9
	Routing table	9-13
NS-Designer	Network No.	} 9-14
	Node No.	
	UPD port No.	
	IP address	
	Sub net mask	
	Conversion table	
FinsGateway	Host name	9-16
	Network No.	} 9-2
	Local node No.	
Conversion table		

## 9-2 Setting FinsGateway

To connect NS hardware and a personal computer using Ethernet, you need to make a setting of FinsGateway beforehand. For details of the operation of FinsGateway, refer to the online help of FinsGateway. For details of the Ethernet unit, refer to the manual.

1. Click on [Start] button of Windows and select [Programs] – [Fins Gateway] – [Service Manager].
2. PLC icon is displayed at the lower right position on the screen. Right click the icon and select [Setting].



3. Open the [Basic] tab and select [Services] from the left side of the window.
4. Select "ETN\_UNIT" from [Service Settings] and click on [Start]. (After you click on [Start] button, the status changes to "Start" and the button name changes to "Stop".)



5. Select [Network] – [Network and Units] from the left side of the window.
6. Double click [Ethernet] under [Units] in [Network and Unit Settings] window on the right. [ETN\_UNIT Properties] dialog is displayed.
7. Click on [Network] tab and set [Network Number] and [Local Node Number] as follows. Use default setting for [Communication unit Number].

## Section9 Ethernet Connection

### *NS series Tutorial Manual*

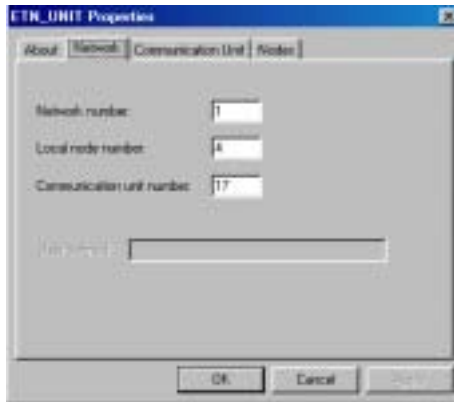

Item	Contents
Network Number	1
Local Node Number	4

### **Reference**

For local node No., set the end number of IP address of a personal computer you are using.

If IP address is 10.3.65.4, set 4.

8. Create a conversion table in [Node] tab. Select [IP address table ] at [FINS-IP conversion] in [Communication Unit] tab. In [Nodes] tab, press [Add] button to display [Ethernet Node Definition] dialog. Add "Node No." and "IP address" of NS hardware and a personal computer. Click on [OK] button.



## Section9 Ethernet Connection

### *NS series Tutorial Manual*

#### NS hardware

Item	Contents
Node number	3
IP address	10.3.65.3

#### Personal computer

Item	Contents
Node number	4
IP address	10.3.65.4

9. After you click on [OK] button, confirmation message to restart FinsGateway is displayed. Click on [Yes].



10. After restarting FinsGateway, open [Nodes] tab again and confirm that the "Model" is not "Unknown". Press [OK] button.



**Reference**

- ◆ With NS-Designer Ver. 2.X and earlier versions, data must be transferred via serial cable or Memory Card before transferring data via Ethernet. This is not necessary with Ver. 3.X or later versions.

11. Select [Exit] from [File] menu.

### 9-3 Setting an Ethernet Unit

With an Ethernet unit, set IP address, unit No and node No.

For details of the Ethernet unit, refer to a manual.

#### Setting an IP address

1. Set an IP address using the rotary switches at the back of Ethernet unit. IP address of PLC1 is 10.3.65.1. Convert this value to hexadecimal and set each switch.

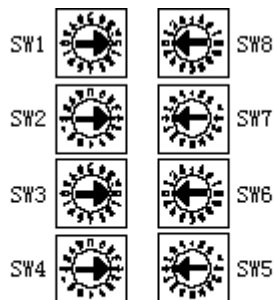

SW No.

Local IP Address 12 . 34 . 56 . 78

Item (SWNo.)	Contents (hexadecimal)	IP Address (decimal)
SW1	0	10
SW2	A	
SW3	0	3
SW4	3	
SW5	4	65
SW6	1	
SW7	0	1
SW8	1	

**Reference**

Rotary SW1 and SW2/SW3 and SW4/SW5 and SW6/SW7 and SW8 make a pair.

SWNO. 1 2 3 4 5 6 7 8

Setting 0 A.0 3.4 1.0 1

IP address 1 0. 3 .6 5. 1

2. Set the IP address 10.3.65.2 of PLC2 in the same manner.

Item (SWNo.)	Contents (hexadecimal)	IP Address (decimal)
SW1	0	10
SW2	A	
SW3	0	3
SW4	3	
SW5	4	65
SW6	1	
SW7	0	2
SW8	2	

**Setting unit No.**

1. Set a unit number using the rotary switch at the front of Ethernet unit.  
Unit No. of PLC1 is 0. Set "0" for "UNIT No." rotary switch.



2. Set "1" for "UNIT No." rotary switch of PLC2 in the same manner.

### Setting a node number

1. Set a node number using the rotary switch at the front of Ethernet unit. Node number at PLC1 side is 1. Set "1" for "NODE No." rotary switch " $\times 16^0$ ", and set "0" for "NODE No." rotary switch " $\times 16^1$ ".



### **Referenece**

When you select auto for conversion type at unit setting in Ethernet unit , set the last digit (SW7,8) of IP address for node number.

2. Set "2" for "NODE No." rotary switch " $\times 16^0$ ", and set "0" for "NODE No." rotary switch " $\times 16^1$ " for PLC2 in the same manner.



## 9-4 Setting a PLC

Set an I/O table and routing table with PLC.

Use CX-Programmer to set these items. For details of the operation method of CX-Programmer, refer to “CX-Programmer Operation Manual (SBCA-305□)”.

### Creating an I/O table

1. Connect PLC1 and a personal computer via peripheral port.  
If you are using a programming console, remove it.

2. Start up CX-Programmer.

3. Select [New] from [File] menu.

In the displayed dialog, set “CS1H” for “Device Type” and set “SYSMAC WAY” for “Network type”.



Click on [Setting] button at the right side of [Device Type] and set [CPU67] for [CPU Type]. Use the default settings for others.

## Section9 Ethernet Connection

### *NS series Tutorial Manual*



4. Click on [OK] button.
5. Select [Work Online] from [PLC] menu.
6. Select [PLC] – [Operating mode] – [Program].
7. Select [PLC] –[EDIT] – [I/O table] and click it.
8. Select [Options] – [Create] in the displayed [PLC I/O table] dialog.

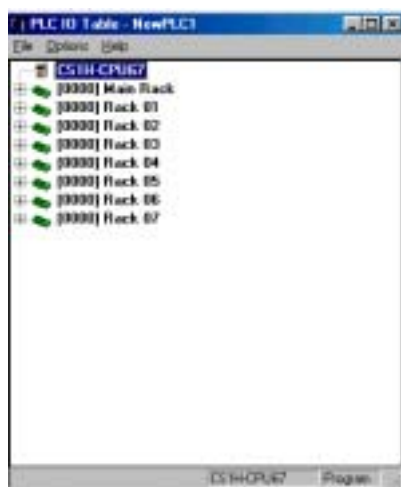

## Section9 Ethernet Connection

### *NS series Tutorial Manual*

9. The message to confirm the creation of I/O table is displayed. Click on [Yes] button.

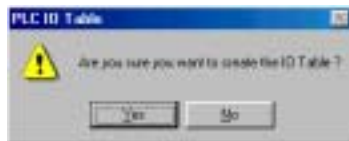

- The message to initialize the CPU bus setting is displayed. Click on [Yes] button.

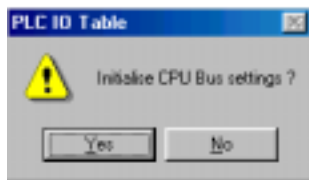

10. Click on  button at the left side of [0030] Main Rack in [PC I/O table] dialog. [Ethernet unit] is displayed.



## Section9 Ethernet Connection

### *NS series Tutorial Manual*

11. Select [Ethernet Unit] and specify [Unit Setup] from the pop-up menu displayed by right clicking of a mouse.
12. Set “Auto” for “Conversion” and set “255.255.255.0” for “Sub-net mask” in [Ethernet CPU Bus Unit] dialog. Use default settings for others.



13. Select [Transfer to PLC] from [Options] menu.
14. Select [Verify] from [Options] menu.
15. Click on [OK] button close [Ethernet CPU Bus Unit] dialog.
16. Select [Transfer to PLC] from [Options] menu in [PC I/O table] dialog.
17. Press [YES] button to close [PC I/O table] dialog.
18. Select [Work Online] from [PLC] menu to disconnect.
19. Perform the setting for PLC2 in the same manner.

## Creating a routing table

1. Select [Network Configuration Tool] from [Tools] menu using CX-Programmer.

The description here is based on Network Configuration Tool Ver1.5. For details of the setting method of prior version, refer to the manual of Network Configuration Tool.



2. Select [New] from [Project] menu. Input CS1H\_1.CDM as a file name.
3. Select [Edit] from [Project] menu.
4. Set [Device list] dialog as shown below.



Item	Contents
[Add] button	CS1H
Device	CS1H
Set (Device) – CPU Type	CPU67
Network	SYSMAC WAY

## Section9 Ethernet Connection

### *NS series Tutorial Manual*

- File name and added PLC are displayed in a main window of Network Configuration Tool. Select PLC name and confirm that the figures of personal computer and PLC at the right side of main window are connected



with a red line.

- Focus on [CS1H] you edited below [CS1H.CDM] then select [Open] from [PLC] menu. Confirm that the line displayed in 5 is changed to green.
- Select [Set] from [Routing table] menu. PC routing table dialog opens.

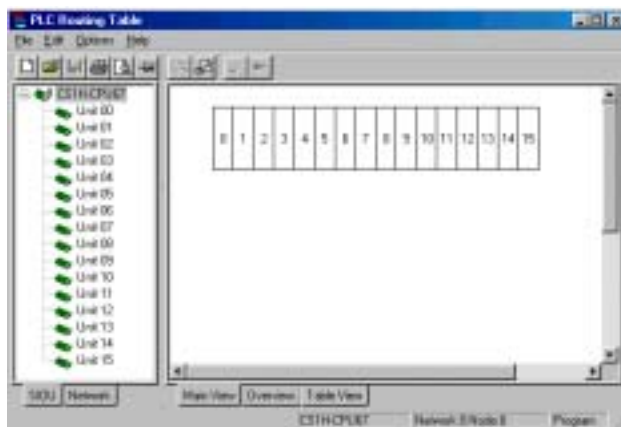

- Select [Add local network] from [Edit] menu.

9. Set [Enter SIOU Details] dialog as shown below.



Item	Contents
CPU SIOU	0
Local network No.	1
Local network type	ENT

10. Click on [OK] button to close [Enter SIOU Details] dialog.

11. Select [Transfer to PLC] from [Options] menu and transfer the setting contents to a PLC.

12. Save the setting contents by selecting [File] – [Save local routing table file] if needed.

13. Close [PLC routing table] dialog.

14. Exit Network Configuration Tool.

## 9-5 Setting at NS-Designer

Perform system settings and host registration with the NS-Designer. By downloading the set data to NS hardware, the settings are overwritten to NS hardware.

1. Start up an NS-Designer and open a project.
2. Select [System setting] from [Settings] menu.
3. Choose [Enable] for [Ethernet] in [Comm-All] tab.



4. Set [Ethernet] tab as shown below.

Item	Contents
Network No.	1
Node No.	3
UDP Port No.	9600
IP Address	10.3.65.3
Sub-net Mask	255.255.255.0

5. Click on [Add] button to open [IP Address setting] dialog.



## Section9 Ethernet Connection

### *NS series Tutorial Manual*

Set PLC1 as shown below.

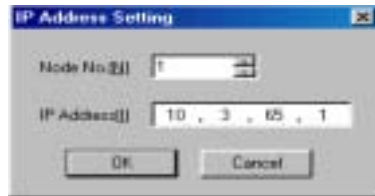

Item	Contents
Node No.	1
IP Address	10.3.65.1

6. Click on [OK] button to close the dialog.
7. Repeat the operations 5 and 6 three times to set PLC2, NS hardware and a personal computer. Set as follows.

## Section9 Ethernet Connection

### *NS series Tutorial Manual*

The screenshot shows the 'System Setting' dialog box with the 'Ethernet' tab selected. The dialog is divided into several sections for configuring network parameters.

**Network Settings:**

- Network Address: 1
- Node Address: 3
- UDP Port No.: 9600
- LAN Speed: 10/100 BASE-T Auto Switch

**IP Address Settings:**

- IP Address: 10 . 3 . 65 . 3
- Subnet Mask: 255 , 255 , 255 , 0
- Default Gateway: 0 . 0 . 0 . 0
- IP Proxy Address: 0 . 0 . 0 . 0

**Conversion Table:**

No.	IP Address
1	10.3.65.1
2	10.3.65.2
3	10.3.65.3
4	10.3.65.4

Buttons: Add, Edit, Delete, OK, Cancel

Section9 Ethernet Connection

**NS series Tutorial Manual**

PLC2

Item	Contents
Node No.	2
IP Address	10.3.65.2

NS hardware

Item	Contents
Node No.	3
IP Address	10.3.65.3

Personal computer

Item	Contents
Node No.	4
IP Address	10.3.65.4

8. Click on [OK] button to close [System Setting] dialog.
9. Select [Register host] from [Settings] menu.
10. Click [Add] button. [Edit host] dialog is displayed.

Set PLC1 as shown below.



Item	Contents
Host Name	CS1H_1
Network No.	1
Node Address	1
PLC Type	SYSMAC-CS1

11. Click on [OK] button to close [Register host] dialog.

## Section9 Ethernet Connection

### *NS series Tutorial Manual*

12. Set PLC2 in the same manner with the procedures10 and 11.

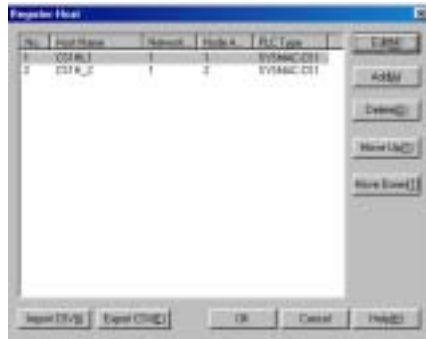

Item	Contents
Host Name	CS1H_2
Network No.	1
Node Address	2
PLC Type	SYSMAC-CS1

13. Click on [OK] button to close [Register host] dialog.

## 9-6 Connecting NS Hardware and a Personal Computer

Connect a personal computer (NS-Designer) and NS hardware to transfer data by Ethernet connection.

Connect an Ethernet cable (10Base-T twisted pair cable) to an Ethernet connector at NS hardware side.

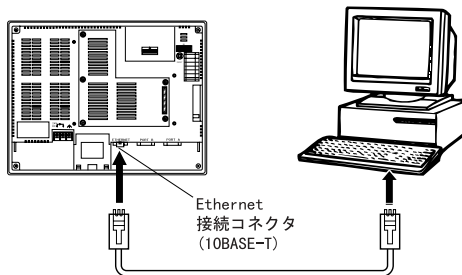

### **Reference**

For details of the communication cable (Ethernet), refer to set up manual "Section2 Preparation before connection".

When data transfer is not possible, check the following points.

- Is the cable connected correctly?
- Is the power for NS hardware ON?
- Check if the starting message which is displayed immediately after turning the power ON is shown?

The first time data is transferred to the PT via Ethernet, it is necessary to set the network address, node address, and IP address beforehand. Make the following settings on the *System Menu – Comm. Tab Page*.

## Section9 Ethernet Connection

### *NS series Tutorial Manual*

Network Address	Set the same address as that set with FinsGateway.
Node Address	Ensure that the PC and PT settings are not the same.
IP Address	Set the same network ID (the underlined parts in the example below) and set the node address as the host ID (the last part of the IP address).

#### Example

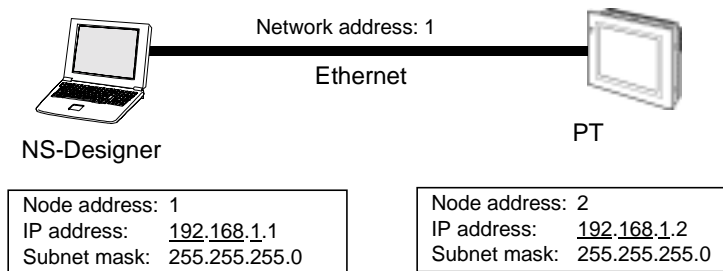

Refer to 6-6-4 *Setting Ethernet* in the *Setup Manual* for details on making settings, such as the IP Address, at the PT.

## 9-7 Transferring Data

Transfer the project data “Project” which you created with an NS-Designer to NS hardware.

1. Select [Transfer Data] from [File] menu.
2. Choose the project to be transferred.  
Select “Project” after clicking [Select Project] button.
3. Set communication method.
  - (1) Click on [Comms. Method] button.
  - (2) Set as shown below.



No.	Item	Contents
1	Communication method	Ethernet
2	Node	3 (10.3.65.3)

(3) Click on [Connect] button.

4. The procedures to follow are the same as the one with RS-232C cable. Refer to “8-3 Transferring Data”.