

General-purpose Relay MK-I/-S

Exceptionally Reliable General-purpose Relay Features Mechanical Indicator/Push Button

- Breaks relatively large load currents despite small size.
- Long life (minimum 100,000 electrical operations) assured by silver contacts.
- Built-in operation indicator (Mechanical, LED), push button, diode surge suppression, varistor surge suppression.
- Standard models are UL, CSA, SEV, DEMKO, NEMKO, SEMKO, TÜV (IEC), and VDE.
- Conforming to CENELEC standards.

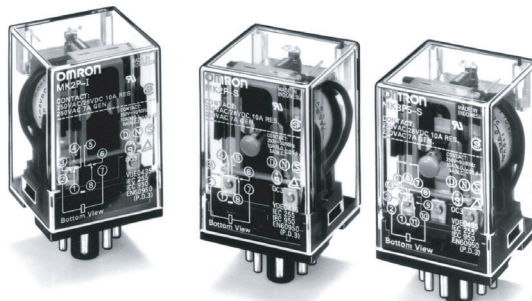

Model Number Structure

Model Number Legend

Standard Models

MK - -

1 2 3 4 5 6

- | | | |
|--|---|--|
| <p>1. Contact Form
2: DPDT
3: 3PDT</p> <p>2. Cover
P: Dust cover</p> | <p>3. Internal Connection Construction
Blank: Standard
2 or 5: Non-standard connection
(Refer to <i>Terminal Arrangement/Internal Connections</i>)</p> <p>4. Mechanical Indicator Push Button
S: Mechanical indicator and push button
I: Mechanical indicator</p> | <p>5. Approved Standards
Blank: UL, CSA, DEMKO, NEMKO
SEMKO, SEV, TÜV
VD: VDE</p> <p>6. Rated Voltage
(Refer to <i>Coil Ratings</i>)</p> |
|--|---|--|

Special Accessories

MK - - -

1 2 3 4 5 6 7 8

- | | | |
|---|---|--|
| <p>1. Contact Form
2: DPDT
3: 3PDT</p> <p>2. Cover
P: Dust cover</p> <p>3. Classification
N: LED indicator
D: Diode
V: Varistor
ND: LED indicator and diode
NV: LED indicator and varistor</p> | <p>4. Coil Polarity
Blank: Standard
1: Reverse
(Refer to <i>Terminal Arrangement/Internal Connections</i>)</p> <p>5. Internal Connection Construction
Blank: Standard
2 or 5: Non-standard connection
(Refer to <i>Terminal Arrangement/Internal Connections</i>)</p> | <p>6. Mechanical Indicator Push Button
S: Mechanical indicator and push button
I: Mechanical indicator</p> <p>7. Approved Standards
Blank: UL and CSA only
VD: VDE (N and D models only)</p> <p>8. Rated Voltage
(Refer to <i>Coil Ratings</i>)</p> |
|---|---|--|

Ordering Information

List of Models

Type	Terminal	Contact form	Internal connection (see note 3)	With mechanical indicator	With mechanical indicator and pushbutton	Coil ratings	Approved standards			
Standard	Plug-in	DPDT	Standard	MK2P-I	MK2P-S	AC (∧), DC (≡)	UL, CSA, SEV, DEMKO, NEMKO, SEMKO, TÜV			
			Non-standard	MK2P2-I	MK2P2-S					
		3PDT	Standard	MK3P-I	MK3P-S					
			Non-standard	MK3P2-I MK3P5-I	MK3P2-S MK3P5-S					
LED Indicator (see note 2)		DPDT	Standard	MK2PN□-I	MK2PN□-S	AC (∧), DC (≡)	UL, CSA			
			Non-standard	MK2PN□-2-I	MK2PN□-2-S					
		3PDT	Standard	MK3PN□-I	MK3PN□-S					
			Non-standard	MK3PN□-2-I MK3PN□-5-I	MK3PN□-2-S MK3PN□-5-S					
Diode (see note 2)		DPDT	Standard	MK2PD□-I	MK2PD□-S	DC (≡)	UL, CSA			
			Non-standard	MK2PD□-2-I	MK2PD□-2-S					
		3PDT	Standard	MK3PD□-I	MK3PD□-S					
			Non-standard	MK3PD□-2-I MK3PD□-5-I	MK3PD□-2-S MK3PD□-5-S					
Varistor		DPDT	Standard	MK2PV-I	MK2PV-S	AC (∧)	UL, CSA			
			Non-standard	MK2PV-2-I	MK2PV-2-S					
		3PDT	Standard	MK3PV-I	MK3PV-S					
			Non-standard	MK3PV-2-I MK3PV-5-I	MK3PV-2-S MK3PV-5-S					
VDE approved		DPDT	Standard	MK2P-I-VD	MK2P-S-VD	AC (∧), DC (≡)	UL, CSA, SEV, DEMKO, NEMKO, SEMKO, TÜV, VDE			
			Non-standard	MK2P2-I-VD	MK2P2-S-VD					
		3PDT	Standard	MK3P-I-VD	MK3P-S-VD					
			Non-standard	MK3P2-I-VD MK3P5-I-VD	MK3P2-S-VD MK3P5-S-VD					
LED Indicator VDE approved		DPDT	Standard	MK2PN-I-VD	MK2PN-S-VD	AC (∧), DC (...)	UL, CSA, VDE			
			Non-standard	MK2PN-2-I-VD	MK2PN-2-S-VD					
		3PDT	Standard	MK3PN-I-VD	MK3PN-S-VD					
			Non-standard	MK3PN-2-I-VD MK3PN-5-I-VD	MK3PN-2-S-VD MK3PN-5-S-VD					
			DPDT	Standard	MK2PD-I-VD			MK2PD-S-VD	DC (...)	UL, CSA, VDE
				Non-standard	MK2PD-2-I-VD			MK2PD-2-S-VD		
3PDT	Standard	MK3PD-I-VD	MK3PD-S-VD							
	Non-standard	MK3PD-2-I-VD MK3PD-5-I-VD	MK3PD-2-S-VD MK3PD-5-S-VD							

Note: 1. When ordering, add the rated voltage to the model number. Rated voltages are given in the coil ratings table in *Specifications*.

Example: MK3P5-S 230 VAC
└──────────┘ Rated voltage

2. This DC coil comes in two types: standard coil polarity and reversed coil polarity. Refer to *Terminal Arrangement/Internal Connections*.

Example: MK2PN1-I 24 VDC
└──────────┘ Reverse polarity

3. Refer to *Terminal Arrangement/Internal Connections* for non-standard internal connection.

4. The gold plating thickness depends on the request.

Example: MK3P-I AP3 24 VAC
└──────────┘ Gold plating thickness: 3 μm

Accessories (Order Separately)

Item	Model	
Track-mounted Socket	8-pin type	PF083A-E
	11-pin type	PF113A-E
Hold-down Clip	PFC-A1	

Specifications

■ Coil Ratings

UL, CSA, DEMKO, NEMKO, SEMKO, SEV, TÜV

	Rated voltage	Rated current		Coil resistance	Must operate voltage	Must release voltage	Max. voltage	Power consumption
		60 Hz	50 Hz					
AC (∩)	6 V	360 mA	404 mA	3.9 Ω	80% max. of rated voltage	30% min. of rated voltage	90% to 110% of rated voltage	Approx. 2.3 VA (at 60 Hz) Approx. 2.7 VA (at 50 Hz)
	12 V	180 mA	202 mA	16.9 Ω				
	24 V	88.0 mA	98.0 mA	62.0 Ω				
	50 V	39.0 mA	46.3 mA	330 Ω				
	100 V	24.8 mA	28.4 mA	1,010 Ω				
	110 V	21.0 mA	24.7 mA	1,240 Ω				
	120 V	18.0 mA	20.2 mA	1,520 Ω				
	200 V	12.1 mA	14.2 mA	4,520 Ω				
	220 V	11.0 mA	12.9 mA	5,130 Ω				
	230 V	10.5 mA	12.3 mA	6,170 Ω				
	240 V	9.2 mA	10.3 mA	6,450 Ω				
DC (=)	6 V	255 mA		23.5 Ω	80% max. of rated voltage	15% min. of rated voltage	90% to 110% of rated voltage	Approx. 1.5 W
	12 V	126 mA		95 Ω				
	24 V	56 mA		430 Ω				
	48 V	29.5 mA		1,630 Ω				
	100 V	14.7 mA		6,800 Ω				
	110 V	15.1 mA		7,300 Ω				

VDE

	Rated voltage	Rated current		Coil resistance	Must operate voltage	Must release voltage	Max. voltage	Power consumption
		50 Hz	60 Hz					
AC (∩)	6 V	380 mA	325 mA	4.4 Ω	80% max. of rated voltage	30% min. of rated voltage	90% to 110% of rated voltage	Approx. 2.0 VA (at 60 Hz) Approx. 2.4 VA (at 50 Hz)
	12 V	175 mA	145 mA	19.0 Ω				
	24 V	91.0 mA	76.5 mA	70.7 Ω				
	50 V	42.0 mA	36.0 mA	330 Ω				
	100 V	24.0 mA	20.5 mA	1,150 Ω				
	110 V	21.5 mA	18.0 mA	1,400 Ω				
	120 V	20.0 mA	17.0 mA	1,600 Ω				
	200 V	11.2 mA	9.4 mA	5,110 Ω				
	220 V	10.2 mA	8.7 mA	5,800 Ω				
	230 V	9.6 mA	8.1 mA	6,990 Ω				
	240 V	9.4 mA	7.9 mA	7,400 Ω				
DC (=)	6 V	225 mA		26.7 Ω	80% max. of rated voltage	15% min. of rated voltage	90% to 110% of rated voltage	Approx. 1.3 W
	12 V	116 mA		107 Ω				
	24 V	56.0 mA		440 Ω				
	48 V	29.0 mA		1,660 Ω				
	100 V	13.1 mA		7,660 Ω				
	110 V	12.5 mA		8,720 Ω				

- Note:**
1. The rated current and coil resistance are measured at a coil temperature of 23°C with tolerances of +15%/–20% for AC rated current and ±15% for DC coil resistance.
 2. Performance characteristic data are measured at a coil temperature of 23°C.
 3. ∩ indicates AC and = indicates DC (IEC417 publications).
 4. For 200 VDC applications, a 100-VDC Relay is supplied with a fixed 6.8 kΩ, 30 W resistor. Be sure to connect the resistor in series with the coil.
 5. For models with the LED indicator built in, add an LED current of approximately 0 through 5 mA to the rated current.

■ Contact Ratings

Load	Resistive load ($\cos\phi = 1$)	Inductive load ($\cos\phi = 0.4$)
Contact mechanism	Single	
Contact material	Ag	
Rated load	10 A at 250 VAC 10A at 28 VDC	7 A at 250 VAC
Rated carry current	10 A	
Max. switching voltage	250 VAC, 250 VDC	
Max. switching current	10 A	
Max. switching power	2,500 VA, 280 W	1,750 VA

■ Characteristics

Contact resistance	50 m Ω max.
Operate time	AC: 20 ms max. DC: 30 ms max.
Release time	20 ms max.
Max. operating frequency	Mechanical:18,000 operations/hr Electrical:1,800 operations/hr (under rated load)
Insulation resistance	100 M Ω min. (at 500 VDC)
Dielectric strength	2,500 VAC, 50/60 Hz for 1 min between coil and contacts; 1,000 VAC, 50/60 Hz for 1 min between contacts of same polarity, terminals of the same polarity; 2,500 VAC, 50/60 Hz fro 1 min between current-carrying parts, non-current-carrying parts, and terminals of opposite polarity
Vibration resistance	Destruction:10 to 55 to 10 Hz, 0.75-mm single amplitude (1.5-mm double amplitude) Malfunction:10 to 55 to 10 Hz, 0.5-mm single amplitude (1.0-mm double amplitude)
Shock resistance	Destruction:1,000 m/s ² (approx. 100G) Malfunction:100 m/s ² (approx. 10G);
Endurance	Mechanical:10,000,000 operations min. (at operating frequency of 18,000 operations/hour) Electrical:Refer to <i>Engineering Data</i> .
Error rate (reference value)	10 mA at 1 VDC
Ambient temperature	Operating:-10°C to 40°C (with no icing or condensation)
Ambient humidity	Operating: 5% to 85%
Weight	Approx. 85 g

Note: The data shown are initial values.

■ Approved Standards

The following ratings apply to all models.

UL 508 (File No. E41515)/CSA 22.2 No.0/14 (File No. LR35535)

Coil ratings	Contact ratings	Operations
6 to 110 VDC 6 to 240 VAC	10 A, 28 VDC (resistive) 10 A, 250 VAC (resistive) 7 A, 250 VAC (general use)	100,000 cycles

SEV, DEMKO, NEMKO

Coil ratings	Contact ratings	Operations
6 to 110 V $\overline{\text{---}}$ 6 to 240 V \sim	10 A, 250 V \sim (NO) ($\cos\phi = 1$) 5 A, 250 V \sim (NC) ($\cos\phi = 1$) 10 A, 28 V $\overline{\text{---}}$ (NO) 5 A, 28 V $\overline{\text{---}}$ (NC) 7 A, 250 V \sim ($\cos\phi = 0.4$)	100,000 cycles

SEMKO

Coil ratings	Contact ratings	Operations
6 to 110 V $\overline{\text{---}}$ 6 to 240 V \sim	10 A, 250 V \sim (NO) ($\cos\phi = 1$) 5 A, 250 V \sim (NC) ($\cos\phi = 1$)	100,000 cycles

TÜV (VDE 0435 Teil 201/05'90, IEC 255 Teil 1-00/75, EN 60950/88

(TÜV File No.: R9051410)

Coil ratings	Contact ratings	Conditions	Operations
6, 12, 24, 48, 100 110 V $\overline{\text{---}}$ 6, 12, 24, 50, 100, 110 115, 120, 200, 220 230, 240 V \sim	10 A, 250 V \sim ($\cos\phi = 1$) 10 A, 28 V $\overline{\text{---}}$ 7 A, 250 V \sim ($\cos\phi = 0.4$)	IEC 255-1-00 Item 3.1.4 Pollution Degree 3, Overvoltage Category II Pick up class - class 2 Temperature class - class b	100,000 cycles

VDE (VDE 0435 Teil 201/05'83, IEC 255 Teil 1-00/75)

(VDE File No.: NR 5340)

Coil ratings	Contact ratings	Conditions	Operations
6, 12, 24, 48, 100 110 V $\overline{\text{---}}$ 6, 12, 24, 50, 100, 110 115, 120, 200, 220 230, 240 V \sim	10 A, 250 V \sim ($\cos\phi = 1$) 10 A, 28 V $\overline{\text{---}}$ 7 A, 250 V \sim ($\cos\phi = 0.4$)	C/250 - class 1, class C	100,000 cycles

Engineering Data

■ Electrical Endurance

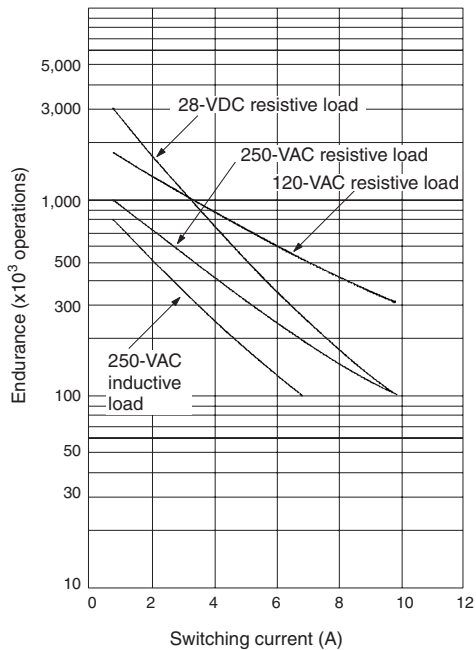

■ Maximum Switching Power

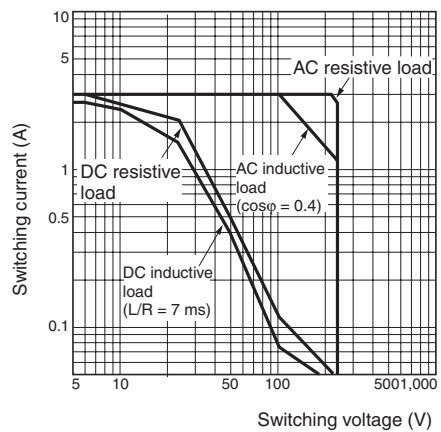

Dimensions

Note: All units are in millimeters unless otherwise indicated.

Relays

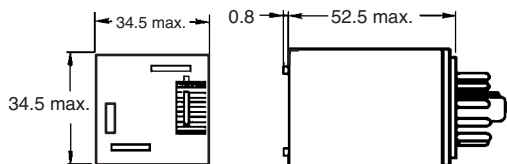

Sockets

See below for Socket dimensions.

Socket	Surface-mounting Socket (for track or screw mounting)	
	Finger-protection models	---
Maximum carry current	10 A	5 A
2 poles	PF083A-E	PF083A
3 poles	PF113A-E	PF113A

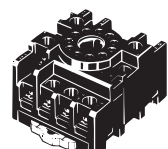
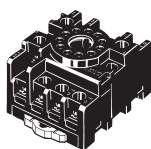

Note: Use the Surface-mounting Sockets (i.e., finger-protection models) with “-E” at the end of the model number. When using the PF083A and PF113A, be sure not to exceed the Socket’s maximum carry current of 5 A. Using at a current exceeding 5 A may lead to burning. Round terminals cannot be used for finger-protection models. Use Y-shaped terminals.

PF083A-E (Conforming to EN 50222)

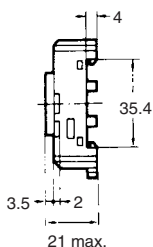
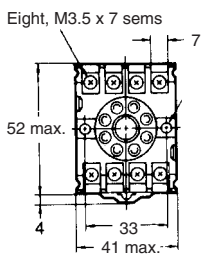

Terminal Arrangement

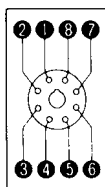

Mounting Holes

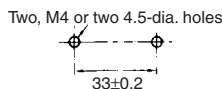

PF113A-E (Conforming to EN 50222)

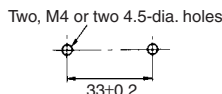
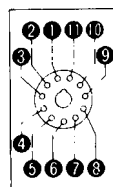
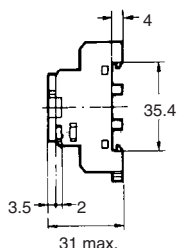
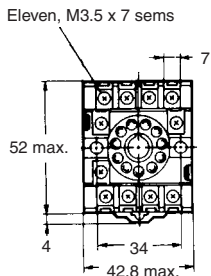

Hold-down Clips

PFC-A1

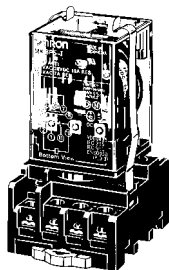

Mounting Tracks

PFP-100N, PFP-50N
(Conforming to EN 50022)

PFP-100N2
(Conforming to EN 50022)

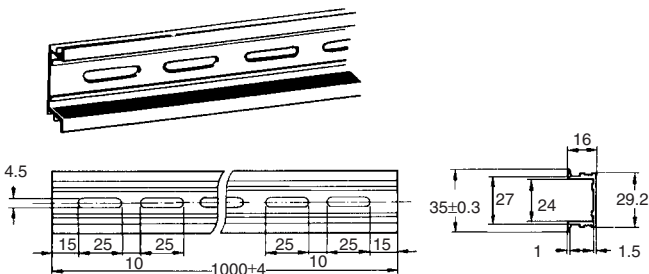
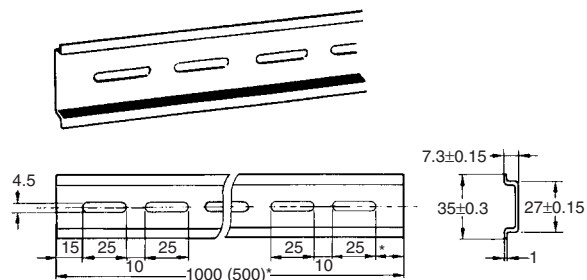

* This dimension applies to the PFP-50N Mounting Track.

* A total of twelve 25 x 4.5 elliptic holes is provided with six holes cut from each track end at a pitch of 10 mm.

Mounting Height with Sockets

Surface-mounting Sockets

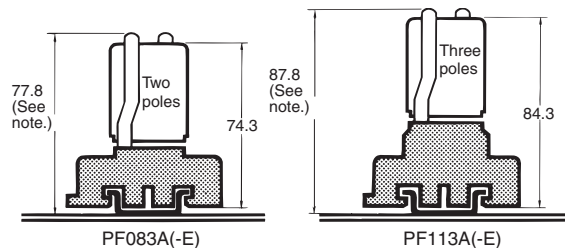

Note: PF083A(-E) and PF113A(-E) allow either track or screw mounting.

Terminal Arrangement/Internal Connection (Bottom View)

Standard
(AC/DC Coil)

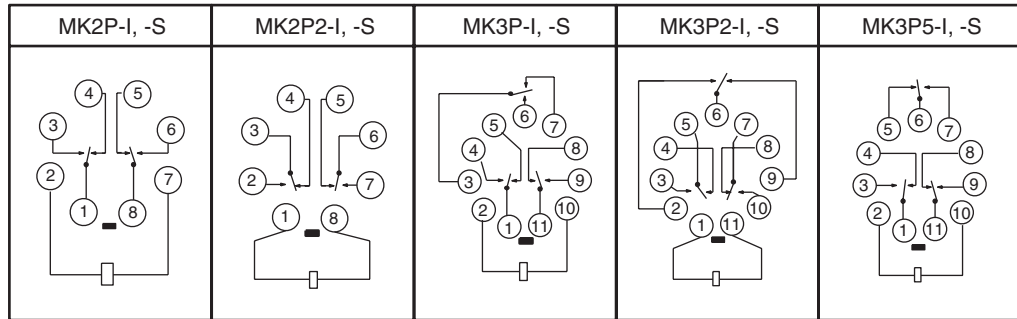

VDE-approved Type
(AC/DC Coil)
(): Dual Numbering

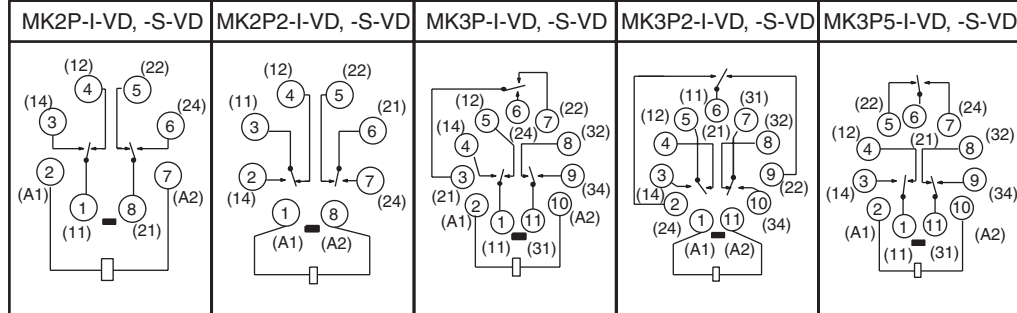

LED Indicator Type
(AC Coil)

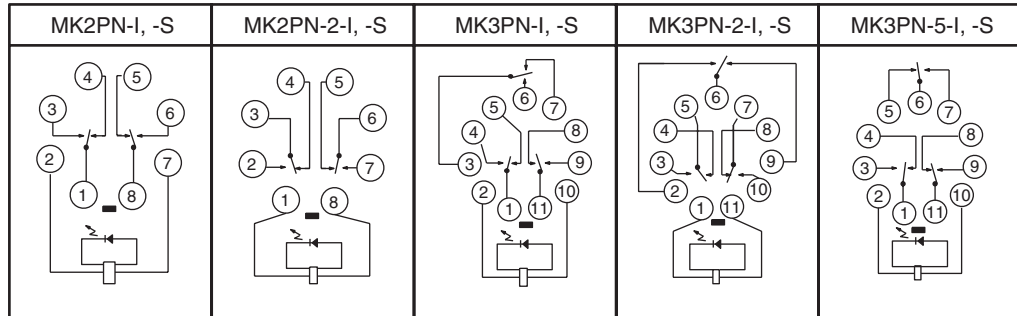

**LED Indicator Type
(DC Coil:
Standard Polarity)**

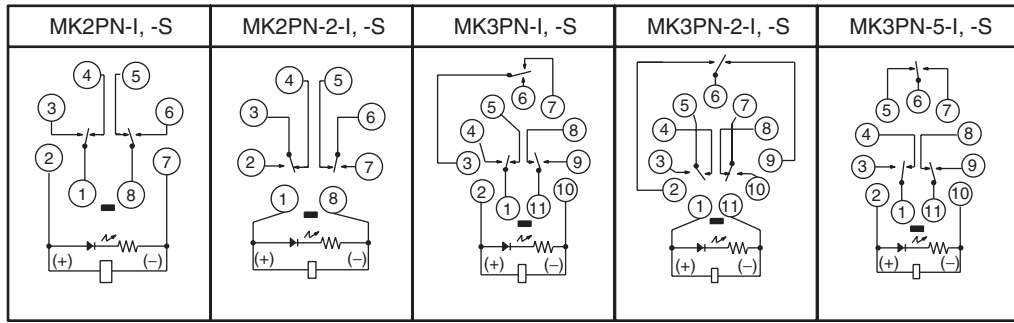

**LED Indicator Type
(DC Coil:
Reverse Polarity)**

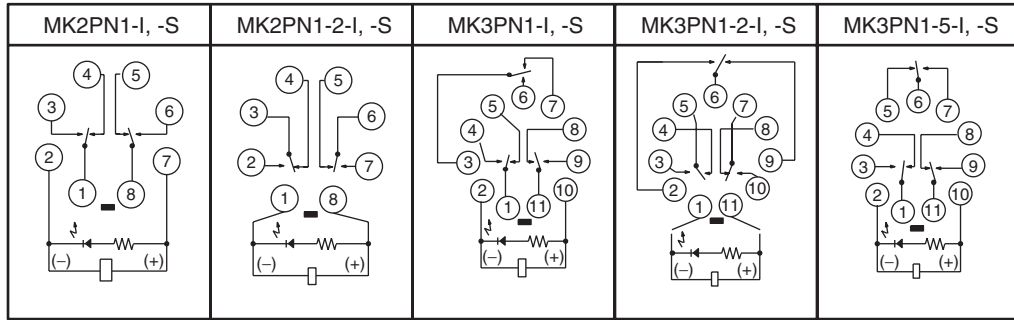

**Diode Type
(DC Coil:
Standard Polarity)**

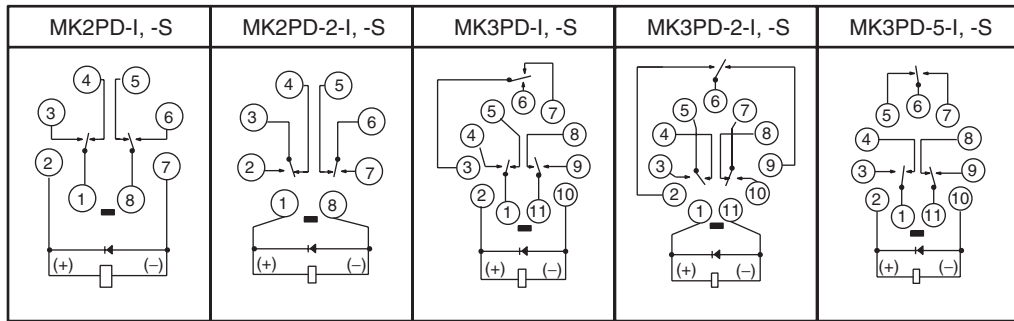

**Diode Type
(DC Coil:
Reverse Polarity)**

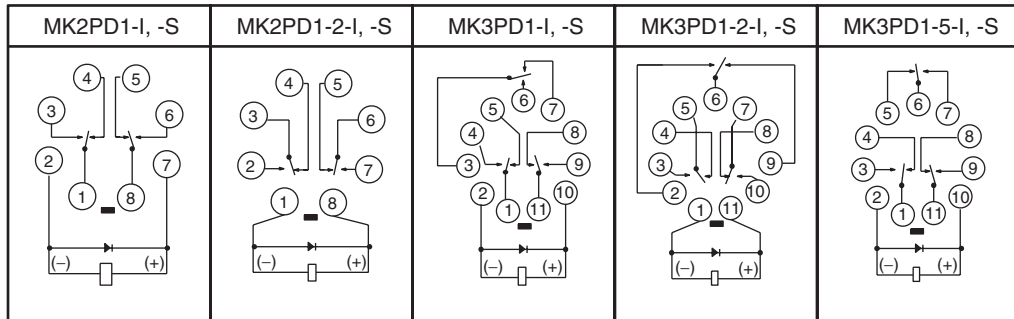

**Varistor Type
(AC Coil)**

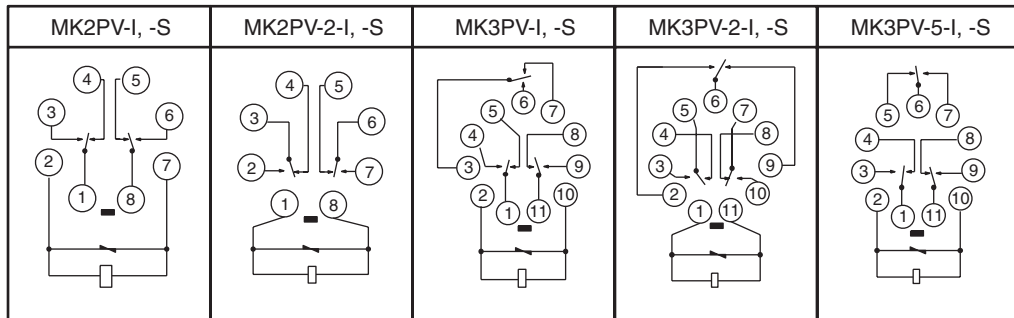

LED Indicator and Diode Type (DC Coil)

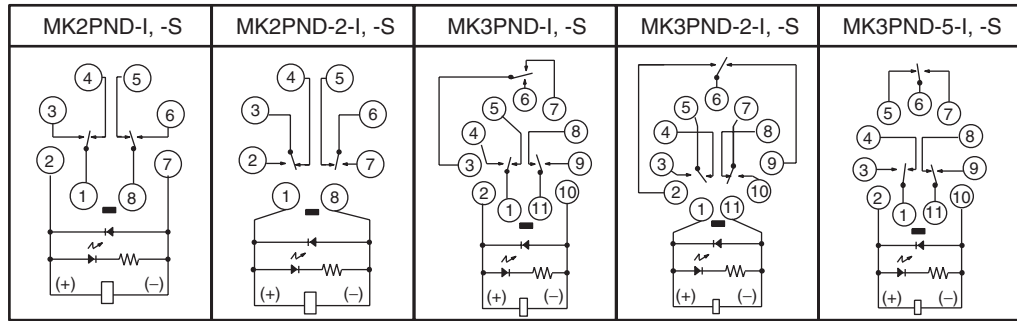

LED Indicator and Varistor Type (AC Coil)

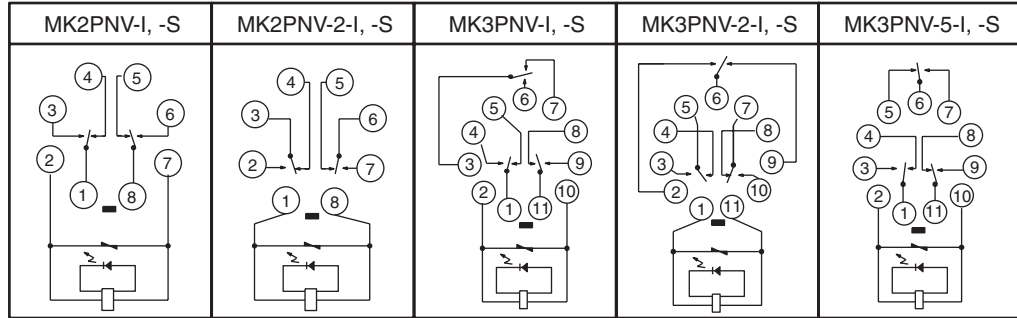

VDE Approved Type LED Indicator Type (DC Coil: Standard Polarity)
(): Dual Numbering

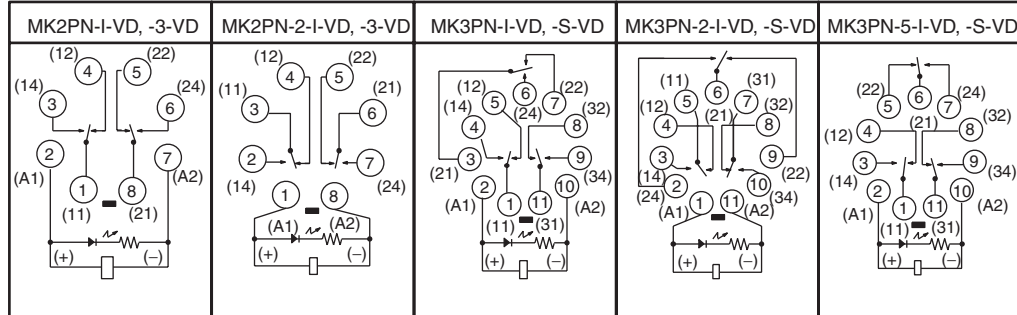

VDE Approved Type LED Indicator Type (DC Coil: Reverse Polarity)

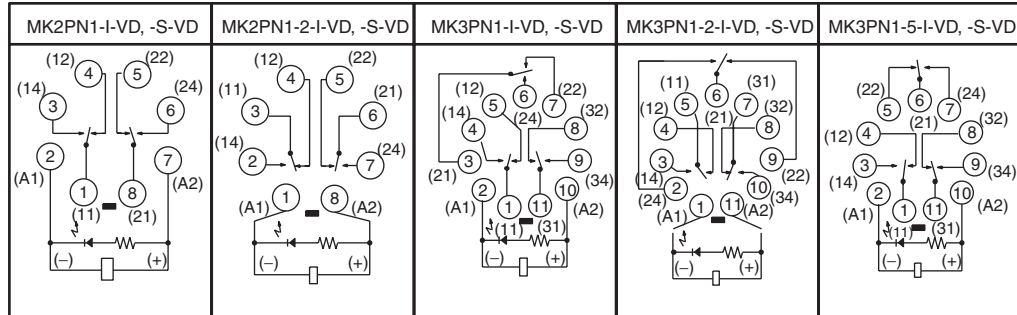

VDE Approved Type Diode Type (DC Coil: Standard Polarity)

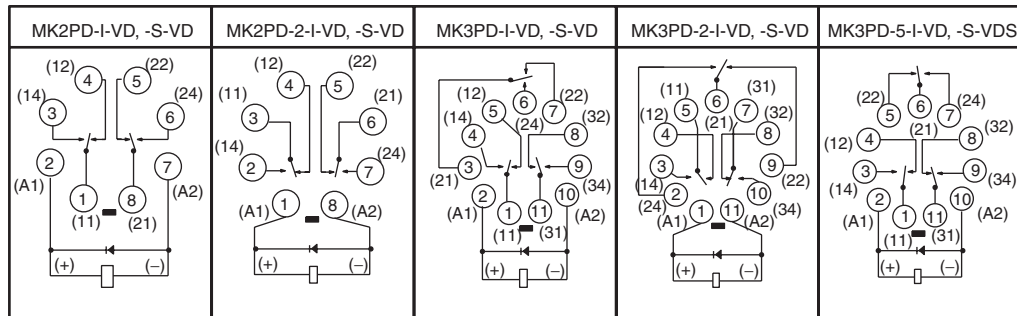

**VDE Approved Type
Diode Type
(DC Coil:
Reverse Polarity)**

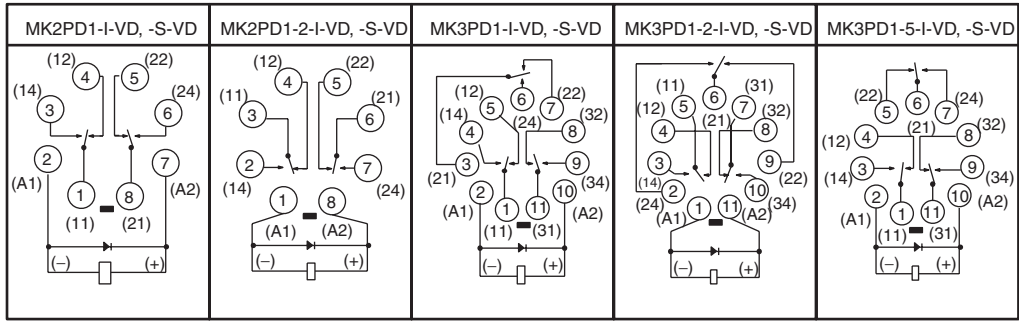

**VDE Approved Type
LED Indicator Type
(AC Coil)**

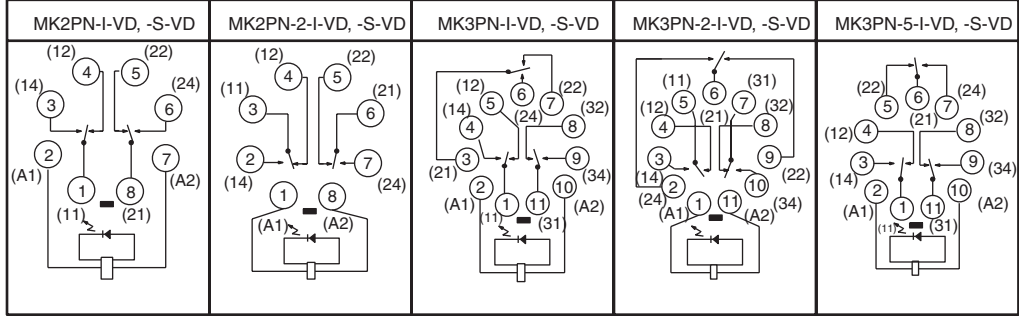

ALL DIMENSIONS SHOWN ARE IN MILLIMETERS.
To convert millimeters into inches, multiply by 0.03937. To convert grams into ounces, multiply by 0.03527.